

ARCHITECTURAL GRATES + DRAINS



100PPSG20

Linear Drainage System

Stormtech is the only linear drainage system available with full Greentag and Watermark certification across our complete product range.

Telephone 01483 346460 | Web slimlinedrain.co.uk





ARCHITECTURAL
GRATES + DRAINS



100PPSG20

Linear Drainage System



100mm Wide Punched Perpendicular Slot Perforated Stainless Steel Grate with uPVC Channel.

The 100PPSG20 slot perforated grate is manufactured from 316 marine grade stainless steel combined with a UPVC drainage channel and offers an affordable option to use the Slimline system.

Kits longer than 3000mm available on request.

Please be aware that depending on the installation environment, for a pool installation or close to a surf beach, you may need to have your stainless steel grates electropolished.

Code 100PPSG20

Range 100

Grate Style PPS

Category Modular Kits

Channel Material uPVC

Steel Grade 316

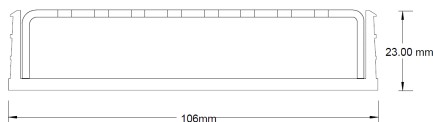

Grates longer than 1500mm supplied in sections.
Tile Inserts longer than 1200mm supplied in sections.
Channels over 3000mm supplied in sections with joiner.

SPECIFICATIONS + DIMENSIONS

| | | | | |
|----------------------|-------------|--------|--------|--------|
| Channel Width | 106mm | | | |
| Channel Depth | 23mm | | | |
| Length(s) | 900mm | 1000mm | 1200mm | 1500mm |
| | 1800mm | 1900mm | 2000mm | 2100mm |
| | 2200mm | 2400mm | 2500mm | 2700mm |
| | 2800mm | 2900mm | 3000mm | |
| Outlet Size | DN80, DN100 | | | |

STORMTECH COLOUR FINISHES

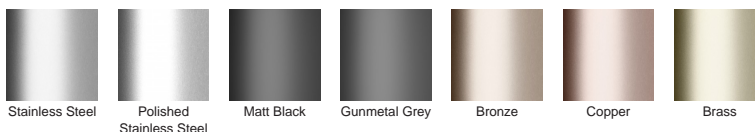

Electroplate finishes subject to natural variation with time and local environment. Factors such as pools/surf beaches may require electropolishing. Contact us for suitability.

PRODUCT APPLICATIONS

- | | |
|-----------------------------|----------------------------|
| Bathroom Drainage | Hospitality Drainage |
| Aged / Health Care Drainage | Paved Area Drainage |
| Balcony Drainage | Shower Drainage |
| Commercial Drainage | Multi-Residential Drainage |
| Courtyard / Patio Drainage | Special Needs Drainage |
| Pool and Spa Area Drainage | Wet Area Drainage |

Copyright © Stormtech Pty Ltd. Patent 733361. Drawings not to scale, please use dimensions shown.



Visit slimlinedrain.co.uk
for tools + inspiration.

Phone 01483 346460

Email technical@slimlinedrain.co.uk

100G20 Assembly

For 100AR20, 100PS20,
100TR20, 100MND20.

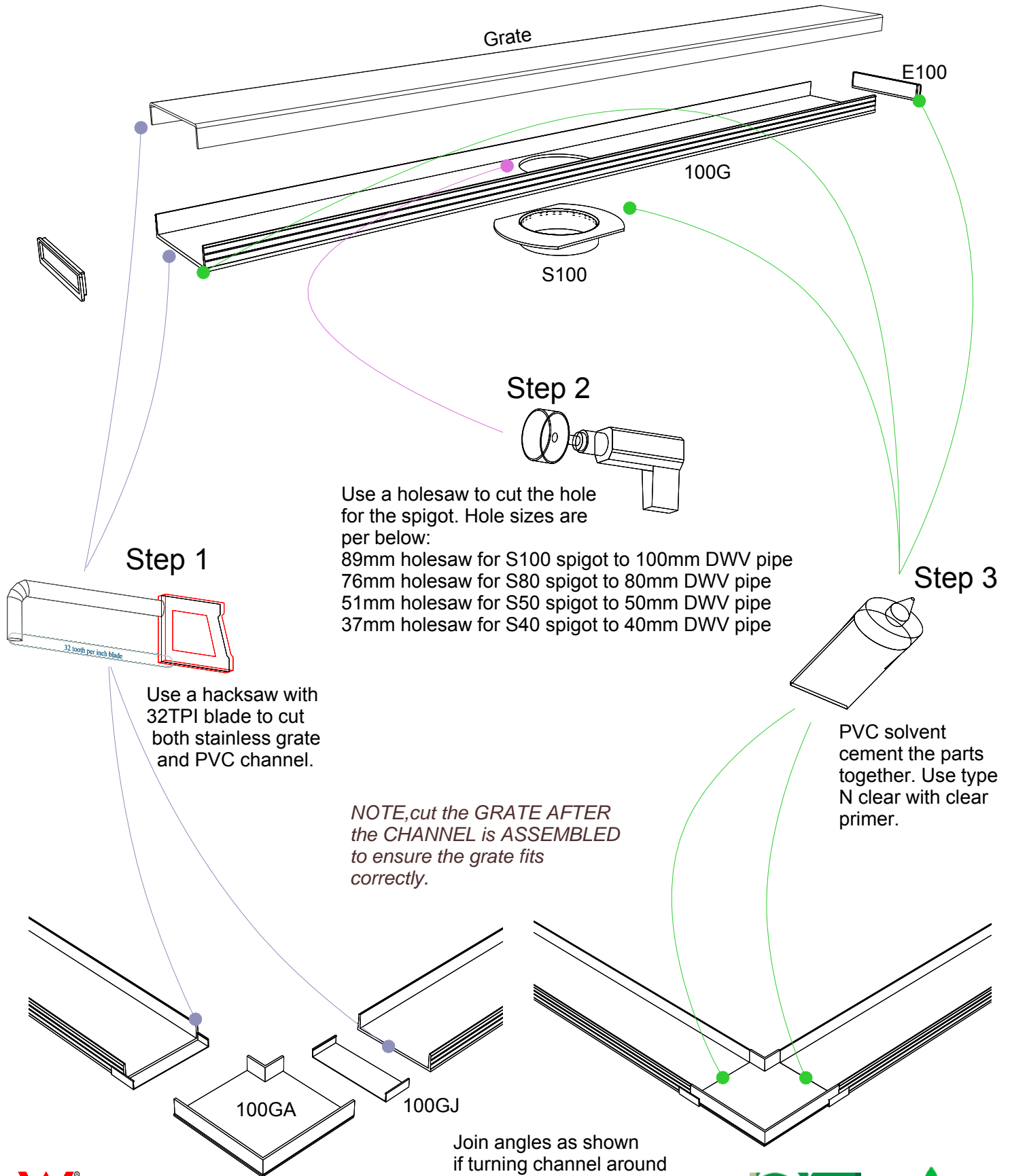

Step 1

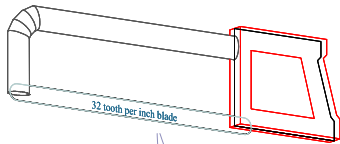

Use a hacksaw with 32TPI blade to cut both stainless grate and PVC channel.

Step 2

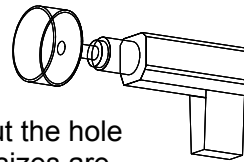

Use a holesaw to cut the hole for the spigot. Hole sizes are per below:

- 89mm holesaw for S100 spigot to 100mm DWV pipe
- 76mm holesaw for S80 spigot to 80mm DWV pipe
- 51mm holesaw for S50 spigot to 50mm DWV pipe
- 37mm holesaw for S40 spigot to 40mm DWV pipe

Step 3

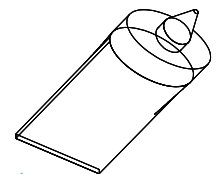

PVC solvent cement the parts together. Use type N clear with clear primer.

NOTE, cut the GRATE AFTER the CHANNEL is ASSEMBLED to ensure the grate fits correctly.

Join angles as shown if turning channel around a 90 degree corner.



100G20 Bathroom

For 100AR20, 100PS20,
100TR20, 100MND20.

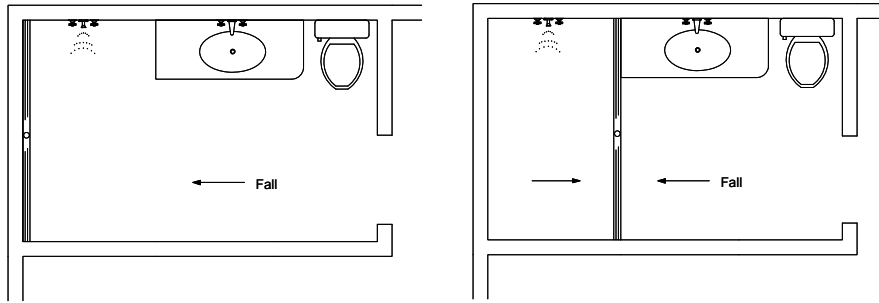

NOTE, ensure pipe sizes and outlet sizes selected are as per requirements in AS3500.

The PSB support fits under the cut grate to support tynes of the grate (100PS only).

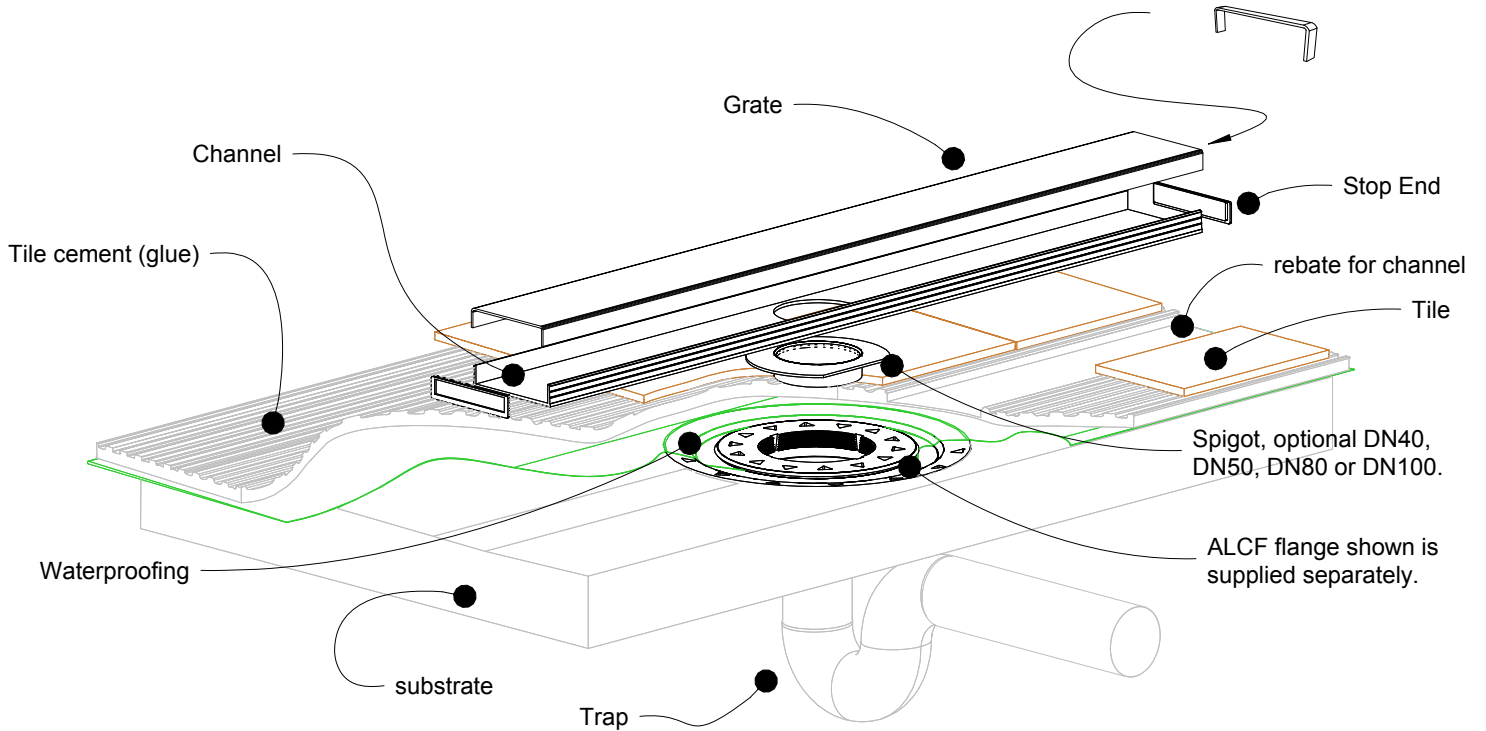

NOTE, this method requires the channel system to be ABOVE and SEPARATE from the WATERPROOFING.

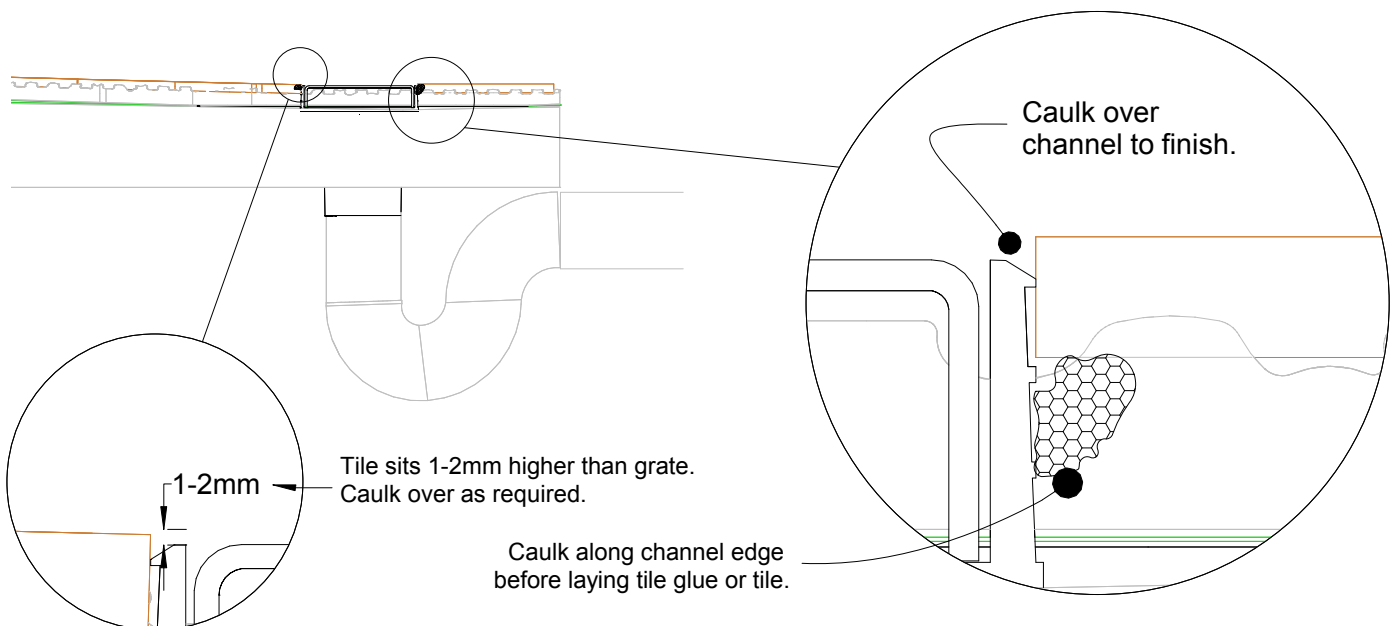

100G20 Concrete Floor or Deck

For 100AR20, 100PS20,
100TR20, 100MND20.



Slab on Ground

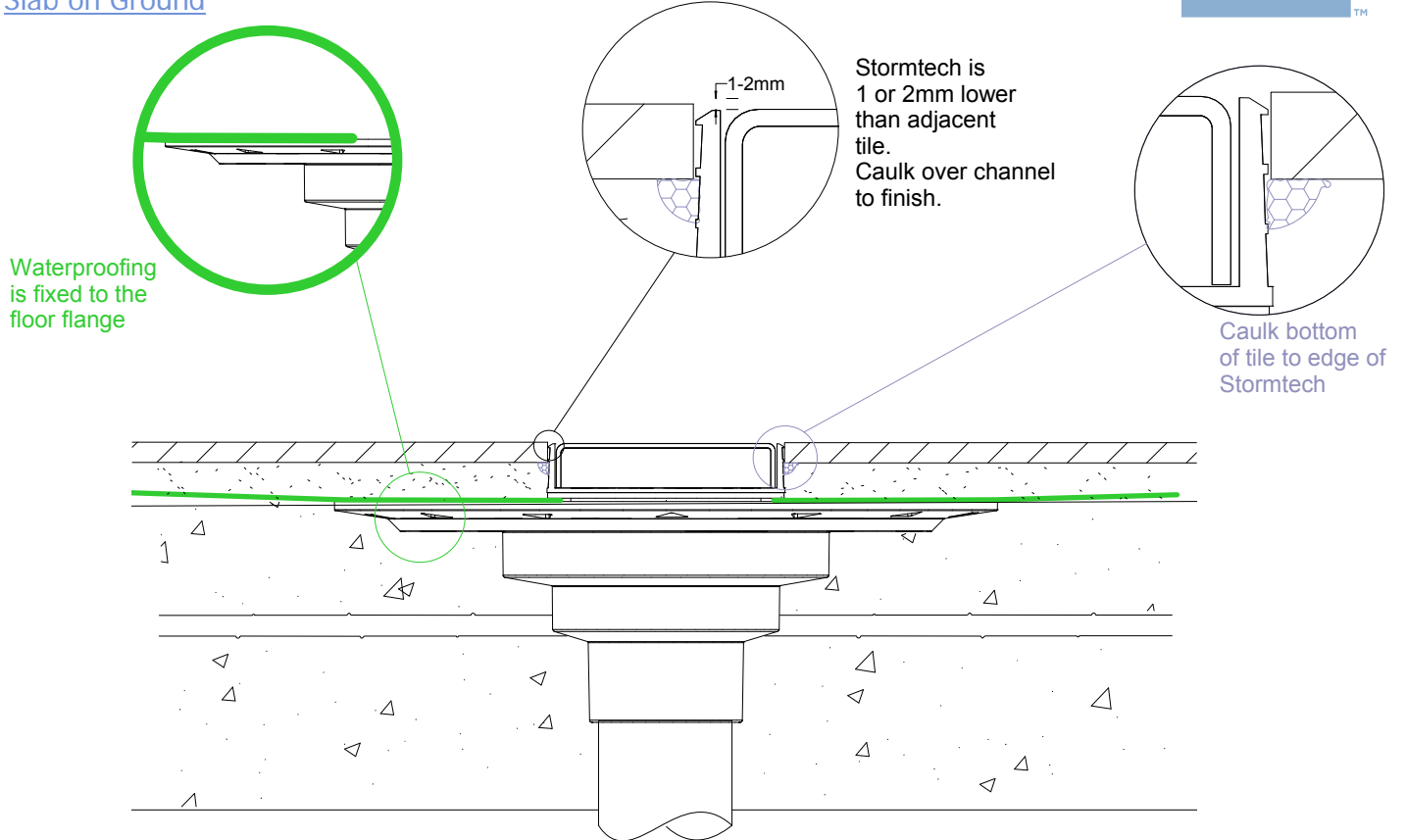

Suspended Slab

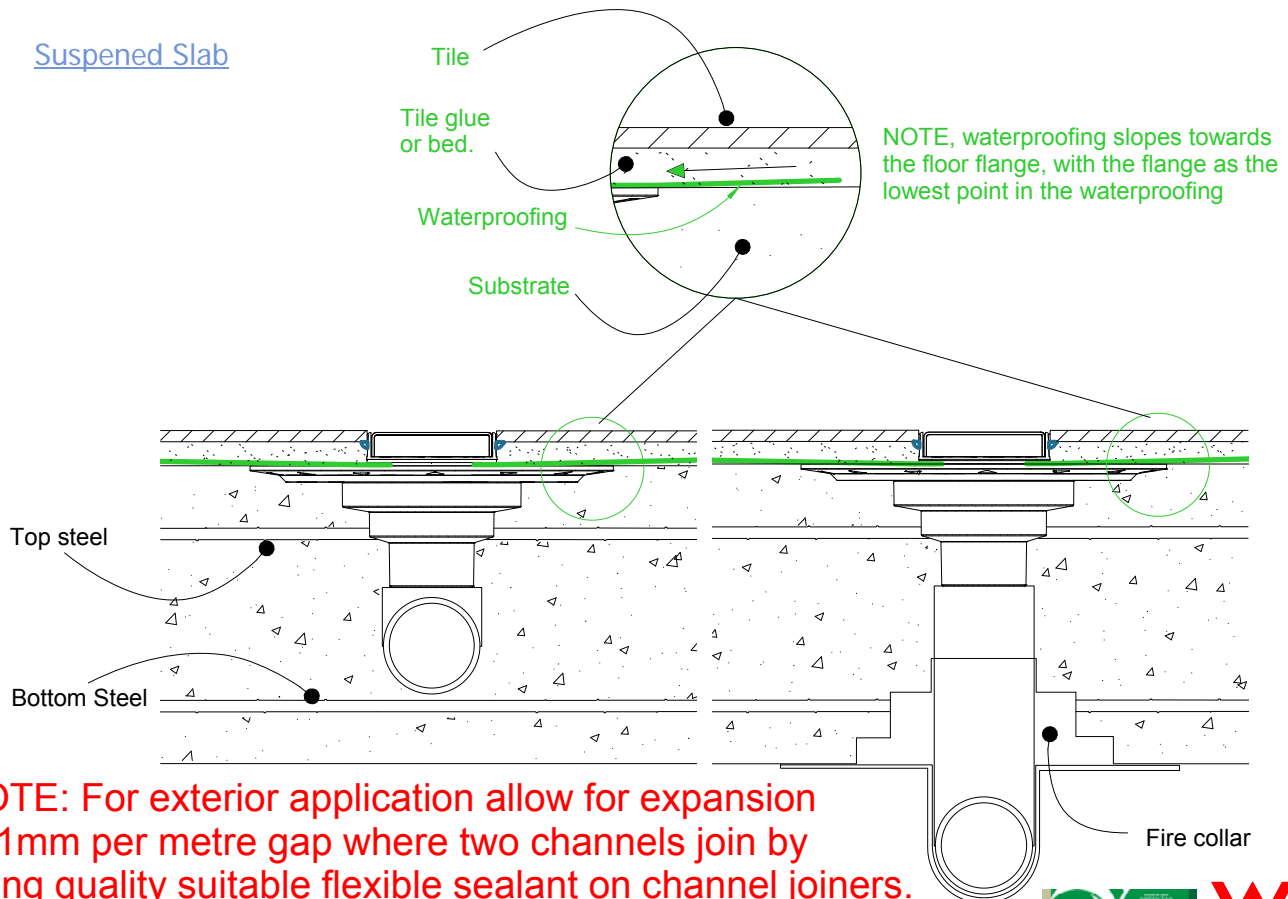

NOTE: For exterior application allow for expansion of 1mm per metre gap where two channels join by using quality suitable flexible sealant on channel joiners. Use PVC solvent cement for ends and outlets.



100G20 Threshold installation suggestion

For 100AR20, 100PS20,
100TR20, 100MND20.



Standard hinged door

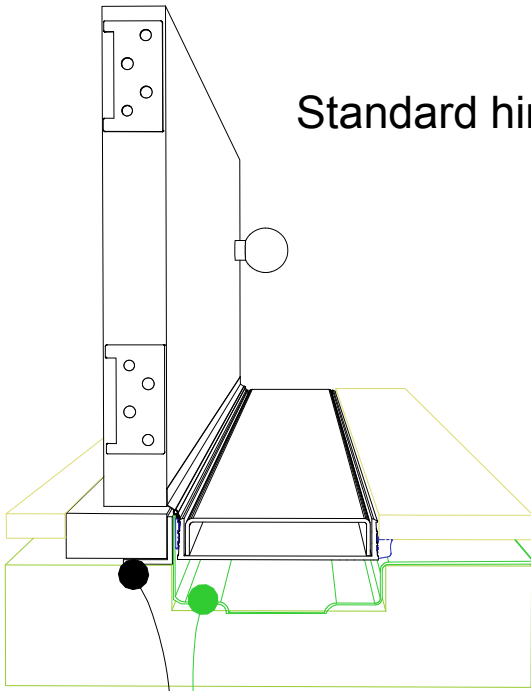

Aluminium angle
to support waterproofing
and junction between channel
and door sil.

Top hung slider

Aluminium angle
to support waterproofing
and junction between channel
and door track.

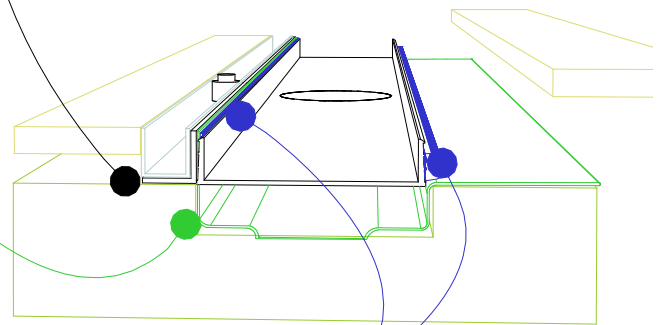
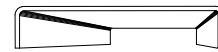

Waterproofing

Bi-fold door

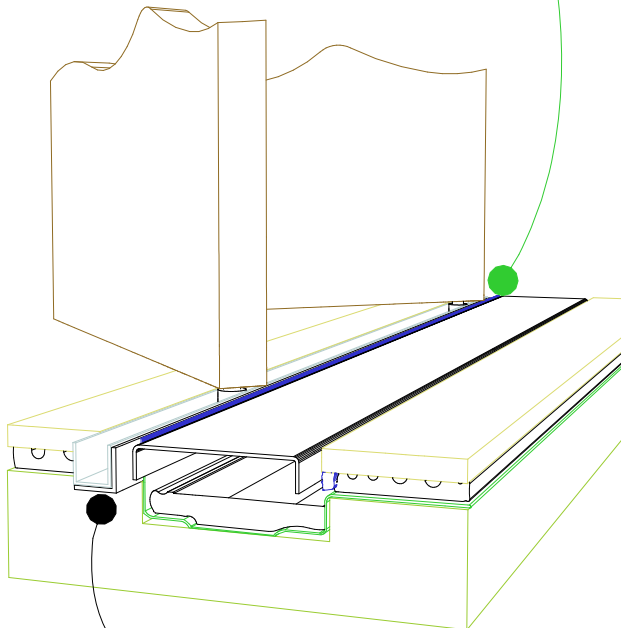

Aluminium angle
to support waterproofing
and junction between channel
and door track.

For all types of threshold
installation ensure both sides
of the channel are sealed
before laying tile.

NOTE, ensure weather stip
is used on the appropriate
side of the door to ensure
drafts and moisture are
minimised.

NOTE, ALWAYS ensure the
waterproofing is completed
before laying the Stormtech.



100ARG20 TIMBER FLOOR/DECK

For 100AR20, 100PS20,
100TR20, 100MND20.



When 100G20 is running parallel to joist/bearer

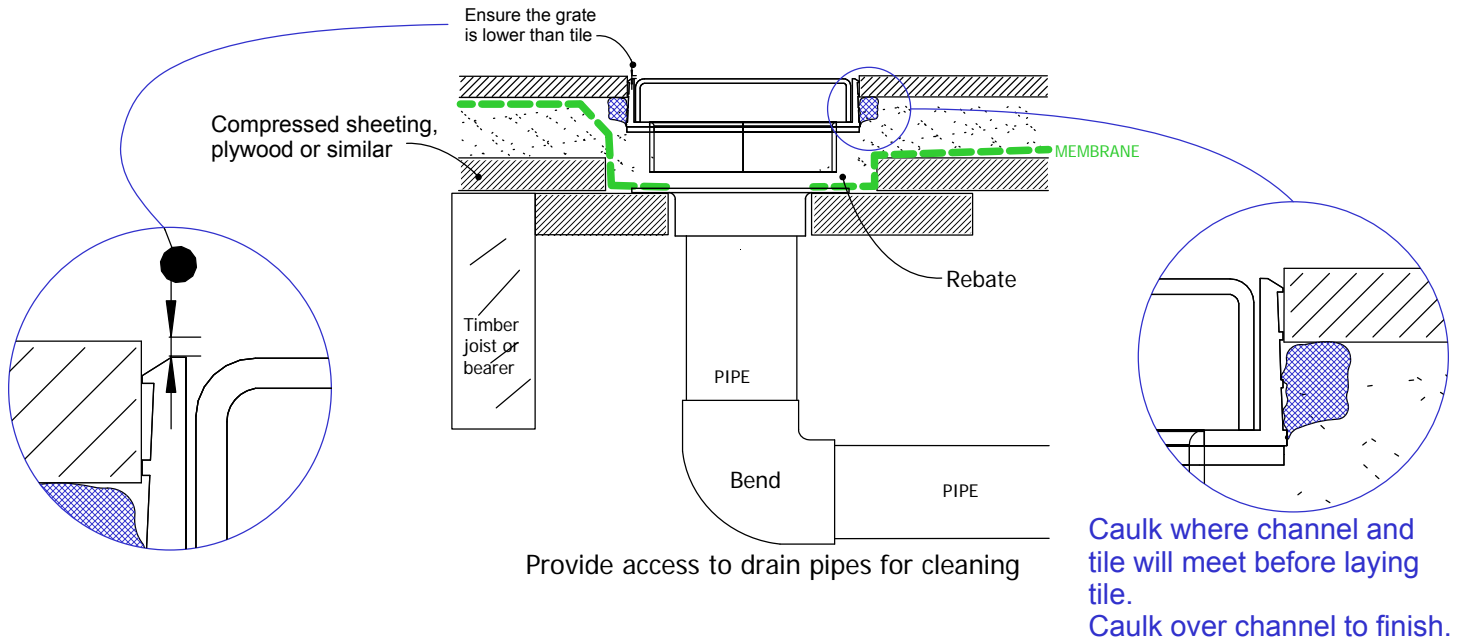

When 100G20 is running perpendicular to joist/bearer

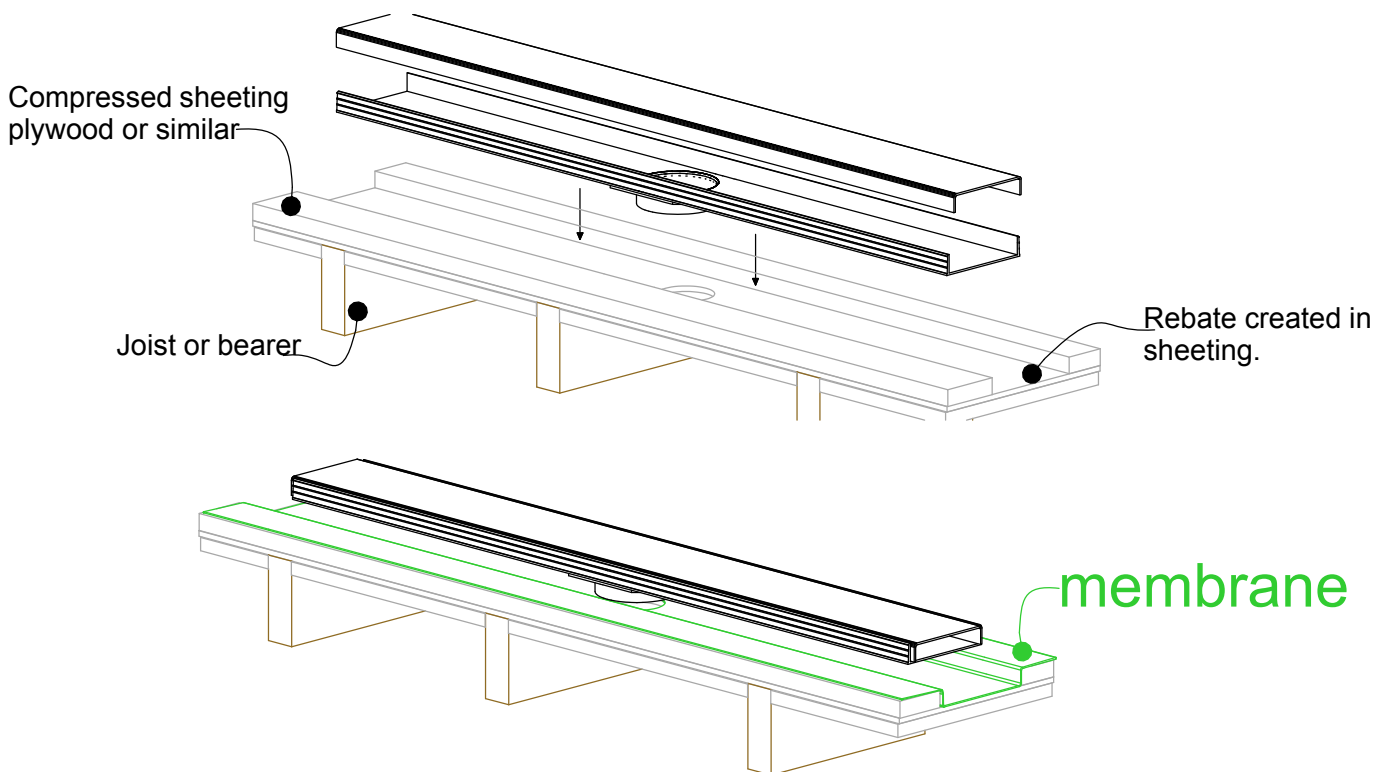

NOTE: For exterior application allow for expansion of 1mm per metre by using quality suitable flexible sealant on channel joins. Use PVC solvent cement and primer on ends and outlets.



100G20 Against Wall

For 100AR20, 100PS20,
100TR20, 100MND20.

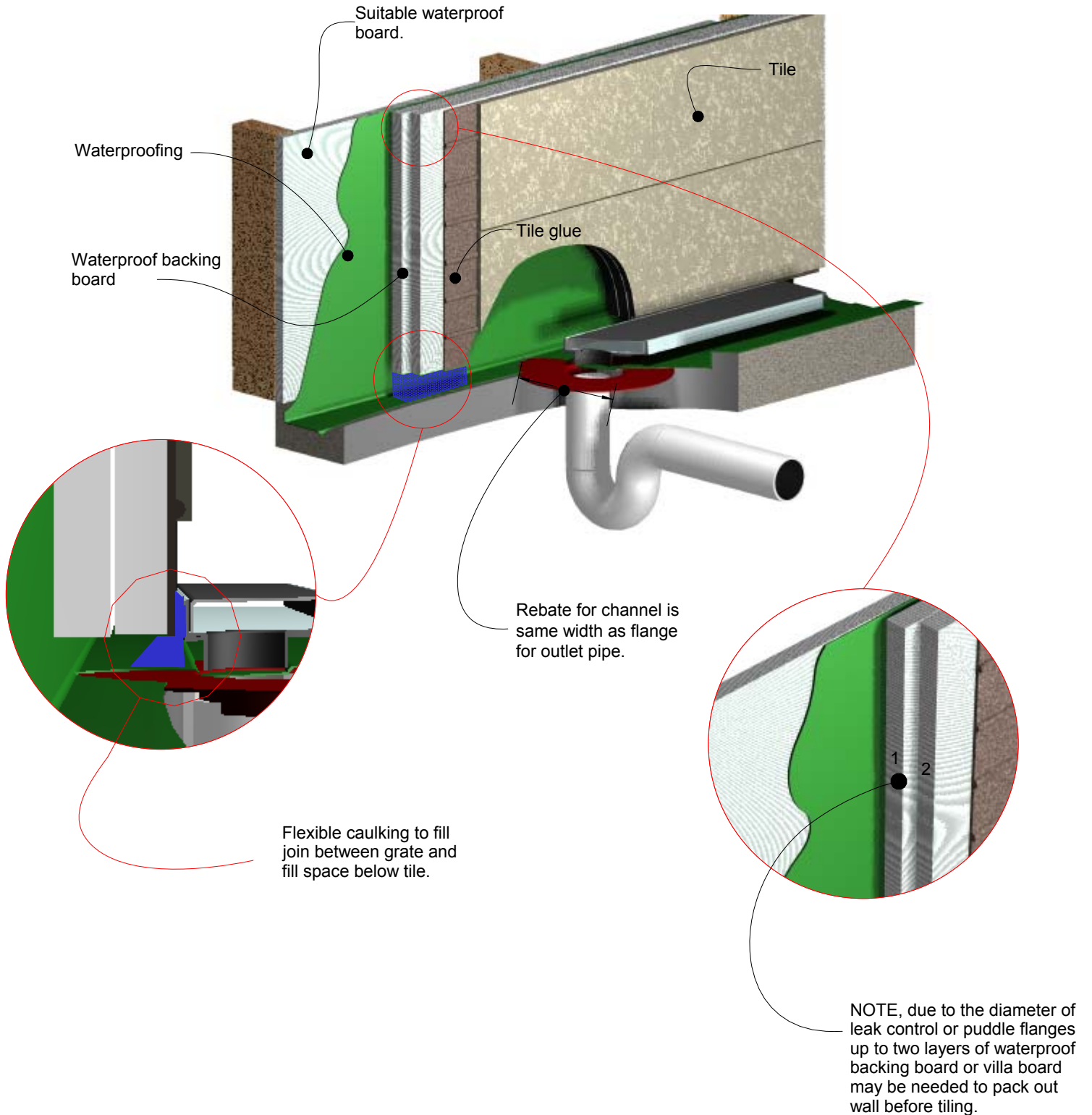

Visit slimlinedrain.co.uk

