

ARCHITECTURAL GRATES + DRAINS



65PSG25

Linear Drainage System

Stormtech is the only linear drainage system available with full Greentag and Watermark certification across our complete product range.

Telephone 01483 346460 | Web slimlinedrain.co.uk





ARCHITECTURAL
GRATES + DRAINS



65PSG25

Linear Drainage System



Modular drainage system with a stainless steel grate and uPVC channel and fittings.

The 65PS is a slot perforated grate design manufactured from 316 marine grade stainless steel. Combined with a UPVC drainage channel it offers an affordable option to use the Slimline system.

Please be aware that depending on the installation environment, for a pool installation or close to a surf beach, you may need to have your stainless steel grates electropolished.

Refer to AS3500 for outlet pipe sizes specific to your installation.

Code 65PSG25

Range 65

Grate Style PS

Category Modular Kits

Channel Material uPVC

Steel Grade 316

SPECIFICATIONS + DIMENSIONS

Channel Width	74mm
Channel Depth	27mm
Length(s)	900mm 1000mm 1200mm 1500mm 1800mm 1900mm 2000mm 2100mm 2200mm 2400mm 2700mm 3000mm
Outlet Size	DN40, DN50

STORMTECH COLOUR FINISHES

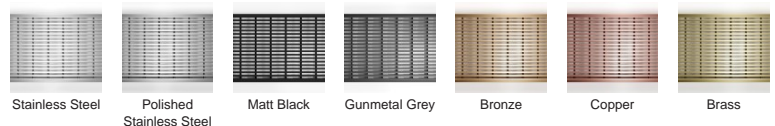

Electroplate finishes subject to natural variation with time and local environment.

PRODUCT APPLICATIONS

- | | |
|-----------------------------|----------------------------|
| Bathroom Drainage | Hospitality Drainage |
| Aged / Health Care Drainage | Paved Area Drainage |
| Balcony Drainage | Shower Drainage |
| Commercial Drainage | Multi-Residential Drainage |
| Courtyard / Patio Drainage | Special Needs Drainage |
| Pool and Spa Area Drainage | Threshold Drainage |

Copyright © Stormtech Pty Ltd. Patent 733361. Drawings not to scale, please use dimensions shown.

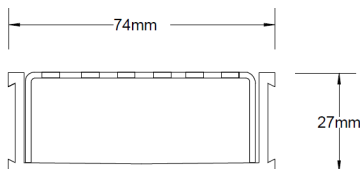

Grates longer than 1500mm supplied in sections.
Tile Inserts longer than 1200mm supplied in sections.
Channels over 3000mm supplied in sections with joiner.



Visit slimlinedrain.co.uk
for tools + inspiration.

Phone 01483 346460

Email technical@slimlinedrain.co.uk

65G25 Assembly

For 65ARG25, 65MNDG25, 65PHG25, 65PSG25, 65TRG25, and 65TRTiG25.



The PDB support fits under the cut grate to support tynes of the grate (65PS only).

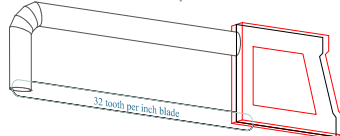
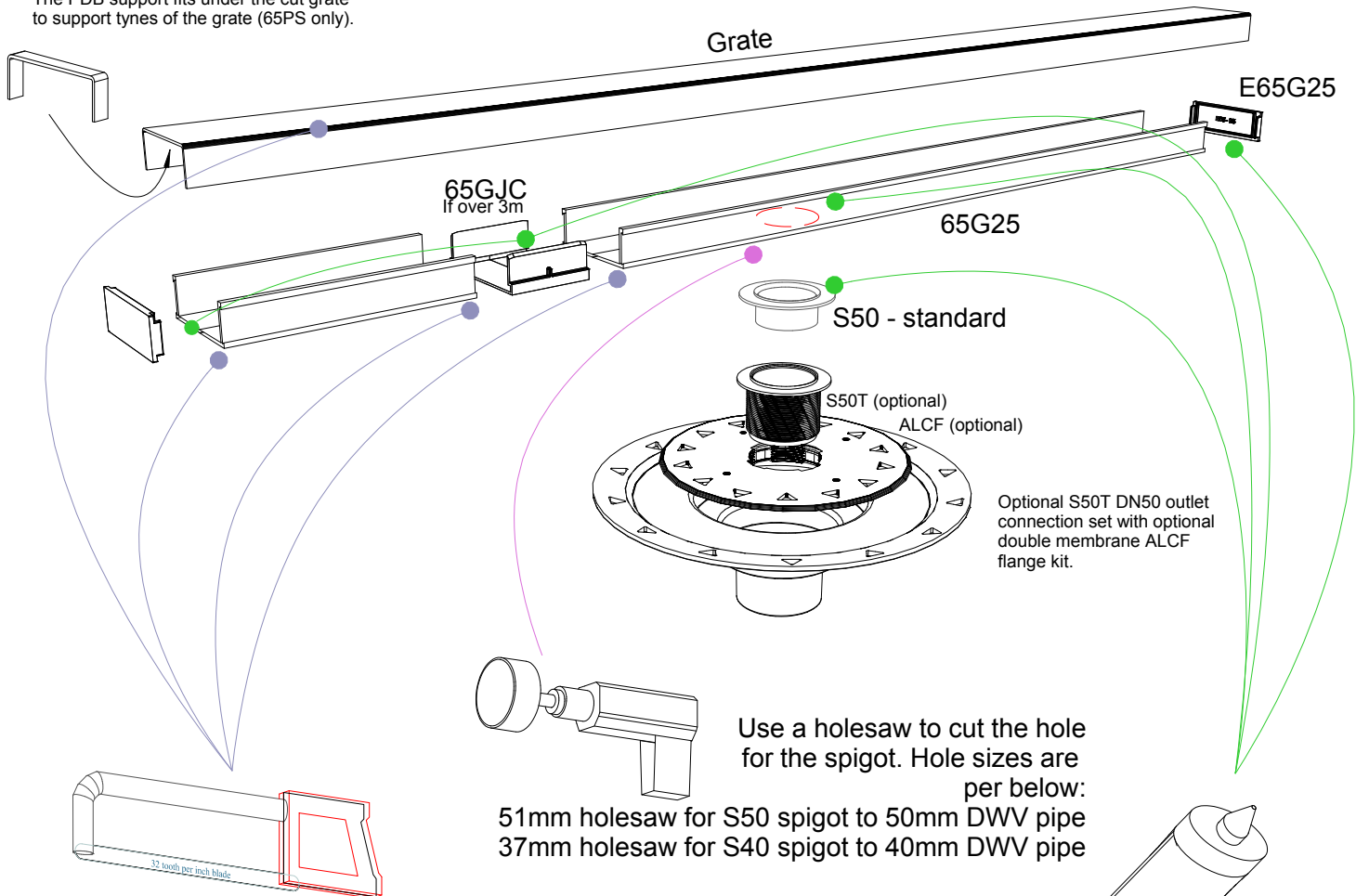

Use a hacksaw with 32TPI blade to cut both stainless grate and PVC channel.
NOTE, cut the GRATE AFTER the CHANNEL is ASSEMBLED. The GRATE will be SHORTER to fit INSIDE the channel.

PVC solvent cement the parts together. Use type N clear with clear primer.

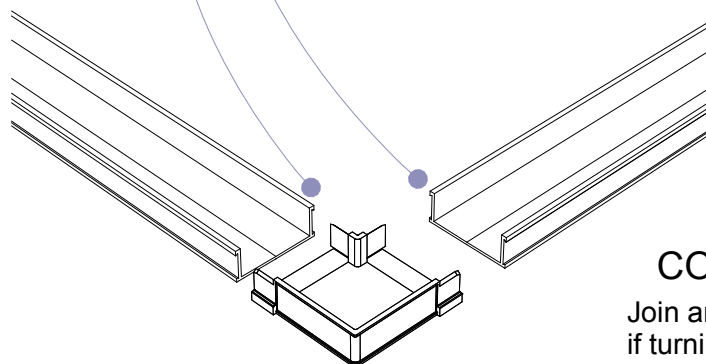

CORNERS

Join angles as shown if turning channel around a 90 degree corner.



65G25 Bathroom

For 65ARG25, 65MNDG25, 65PHG25, 65PSG25, 65TRG25, and 65TRTiG25.

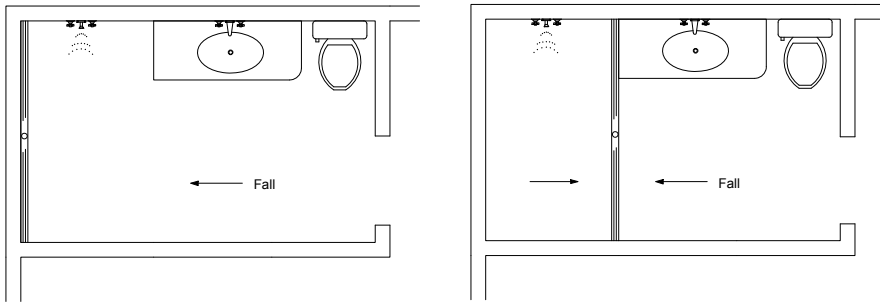

NOTE, refer to AS3500 for specific outlet pipe sizes related to your specific installation.

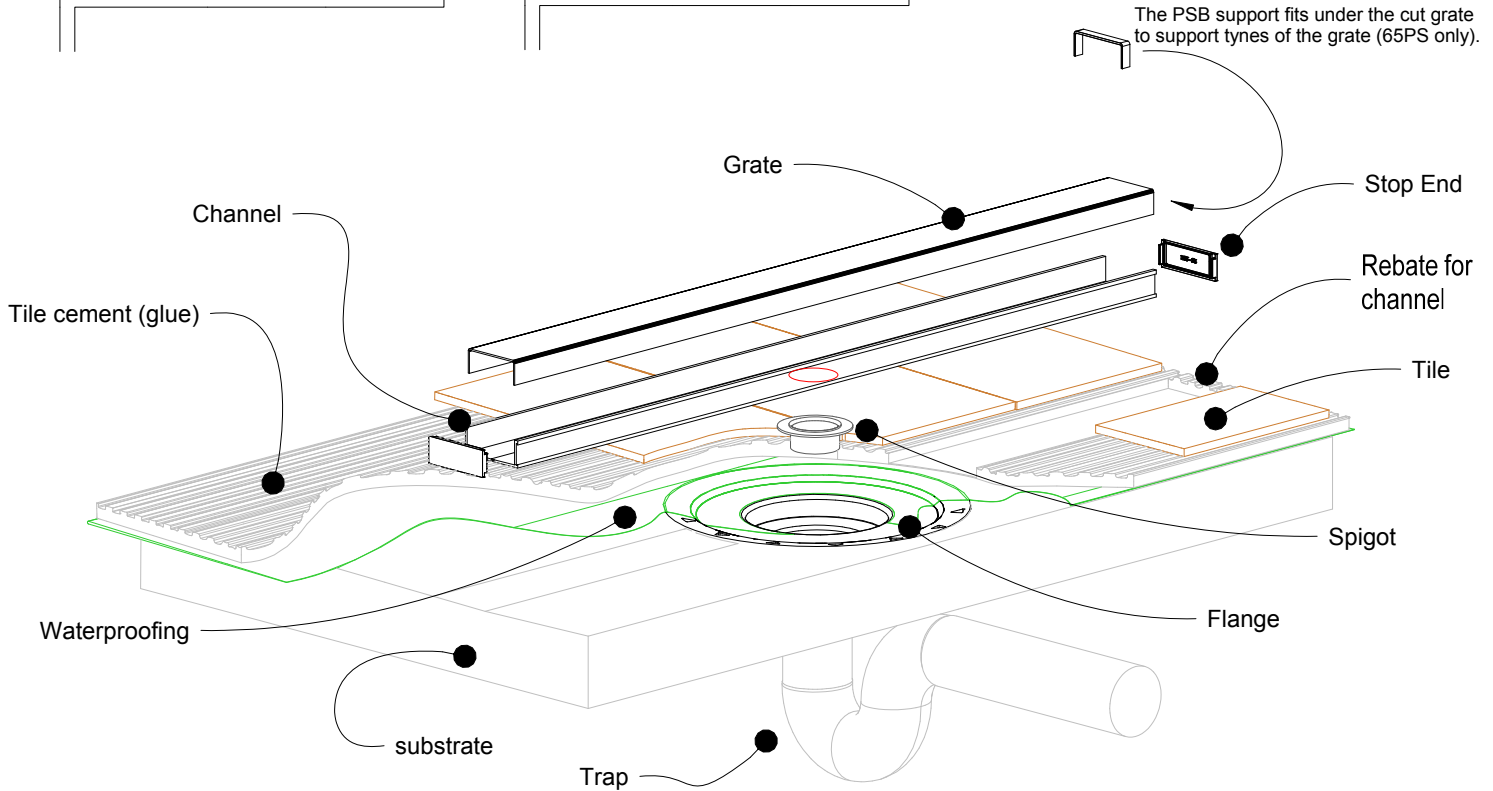

NOTE, this method requires the channel system to be ABOVE and SEPARATE from the WATERPROOFING.

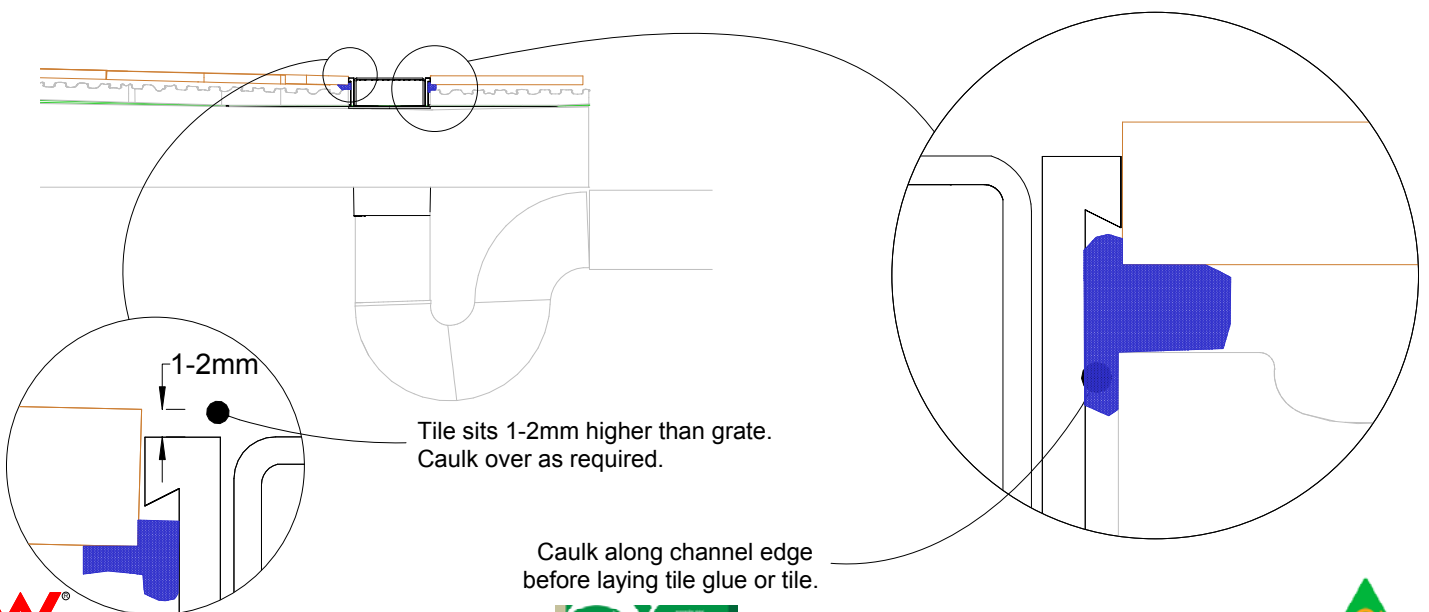

65G25 Concrete Floor or Deck

For 65ARG25, 65MNDG25, 65PHG25, 65PSG25, 65TRG25, and 65TRTiG25.



Slab on Ground

Waterproofing is fixed to the floor flange

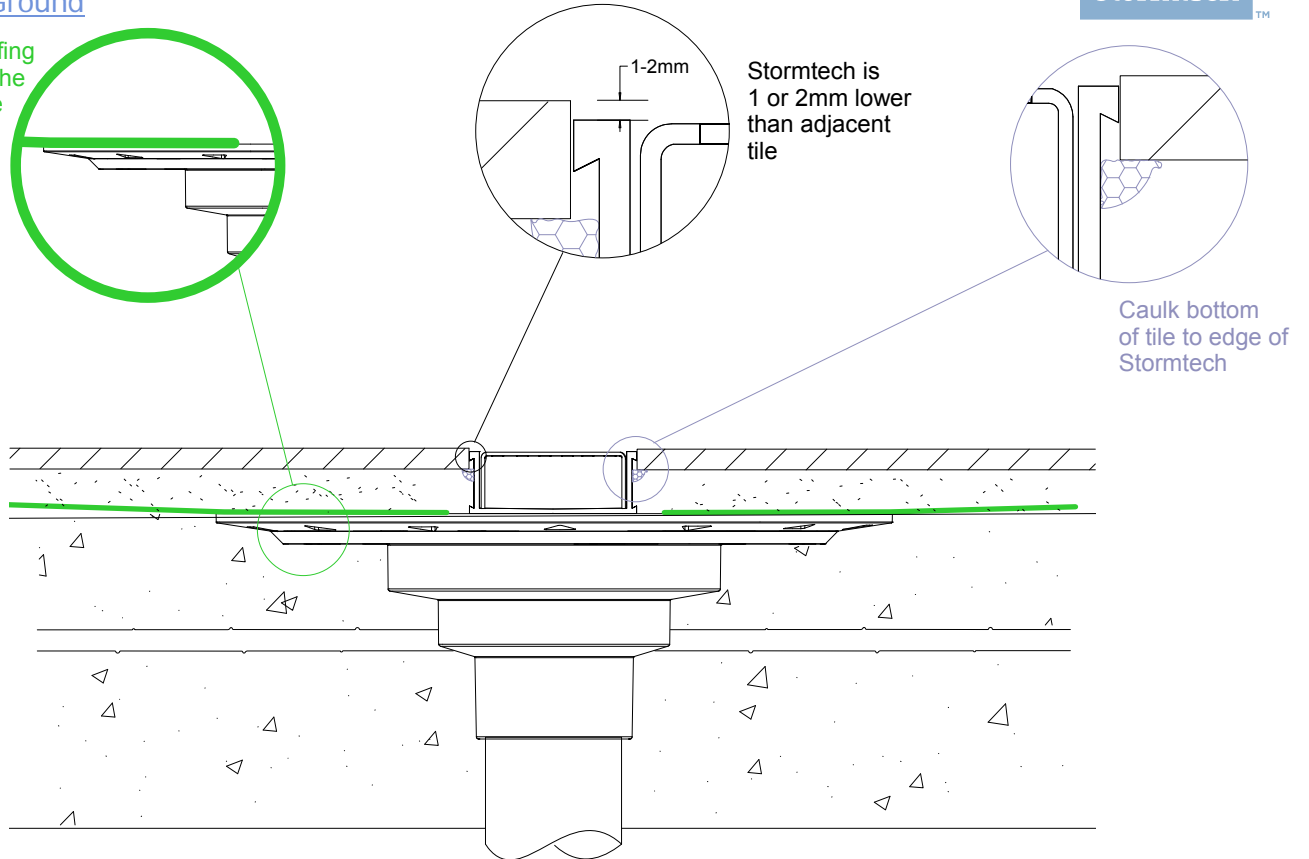

Suspended Slab

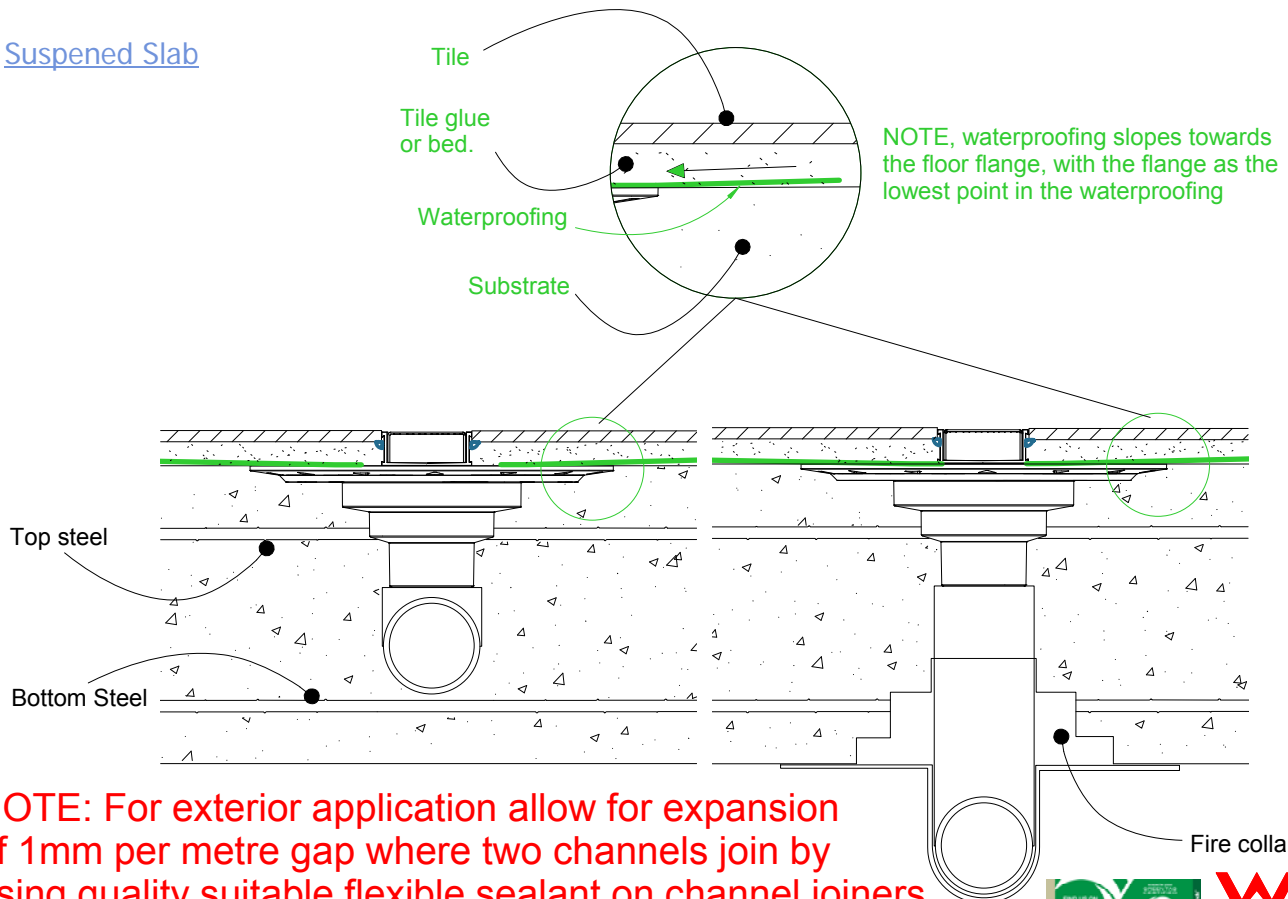

NOTE: For exterior application allow for expansion of 1mm per metre gap where two channels join by using quality suitable flexible sealant on channel joiners. Use PVC solvent cement for ends and outlets.



65G25 Off-Set Corners



When assembling channel for corners other than 90 degrees, the following fittings and method is suggested.

1

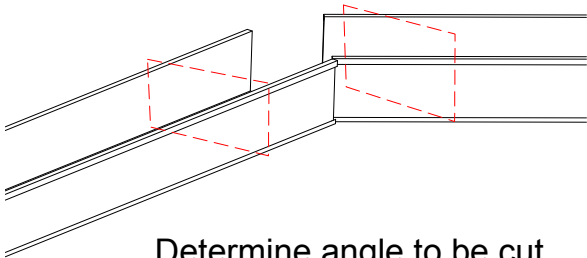

Determine angle to be cut

2

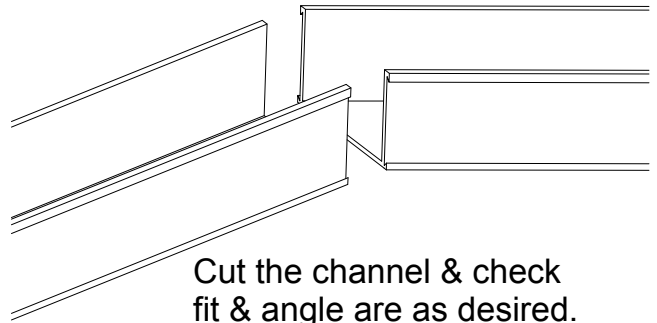

Cut the channel & check fit & angle are as desired.

3

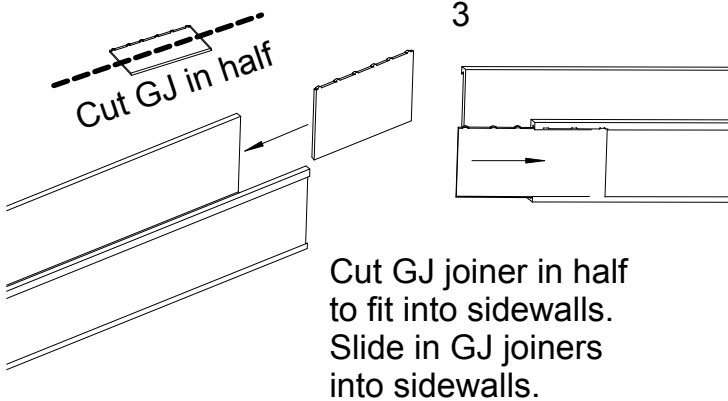

Cut GJ joiner in half to fit into sidewalls. Slide in GJ joiners into sidewalls.

4

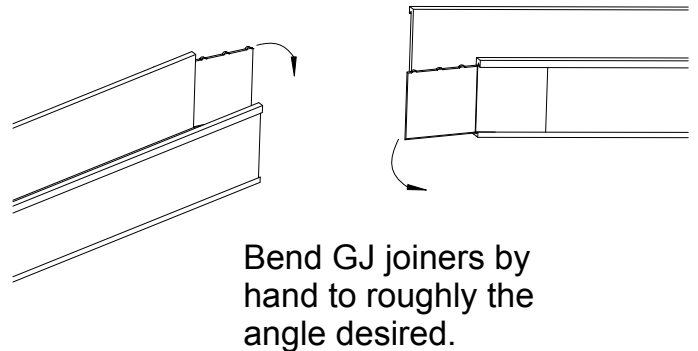

Bend GJ joiners by hand to roughly the angle desired.

5

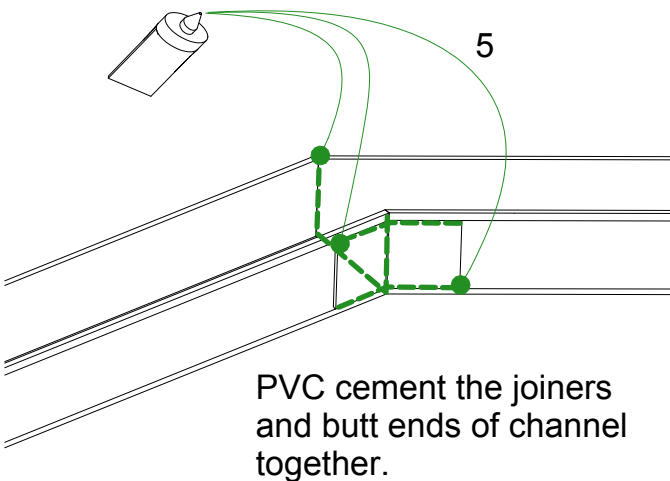

PVC cement the joiners and butt ends of channel together.

6

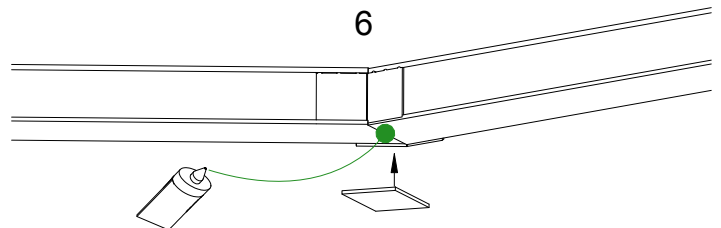

Fix an off-cut of channel to underside to brace joint. Seal with adhesive sealant if joint is uneven.



65G25 Threshold installation suggestion

For 65ARG25, 65MNDG25, 65PHG25, 65PSG25, 65TRG25, and 65TRTiG25.



Standard hinged door

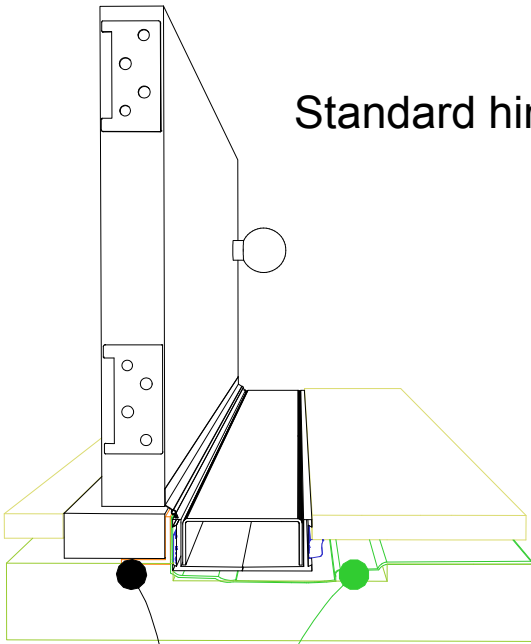

Aluminium angle to support waterproofing and junction between channel and door sil.

Top hung slider

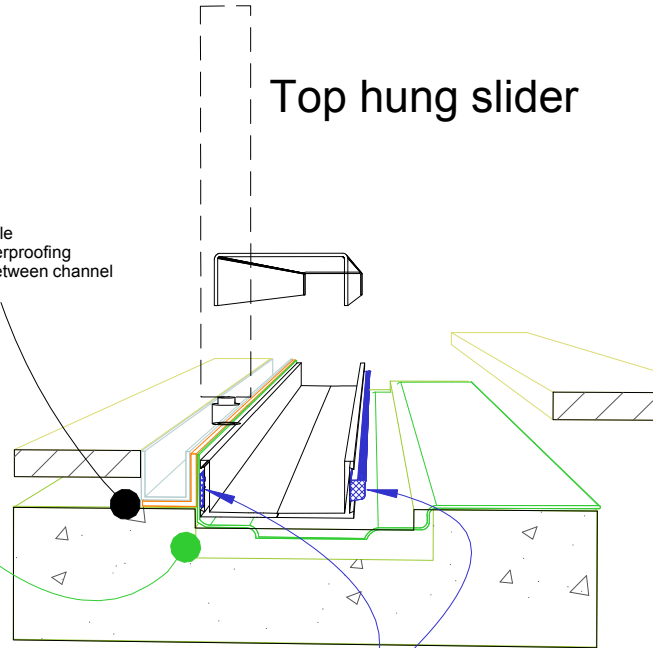

Aluminium angle to support waterproofing and junction between channel and door track.

Waterproofing

Bi-fold door

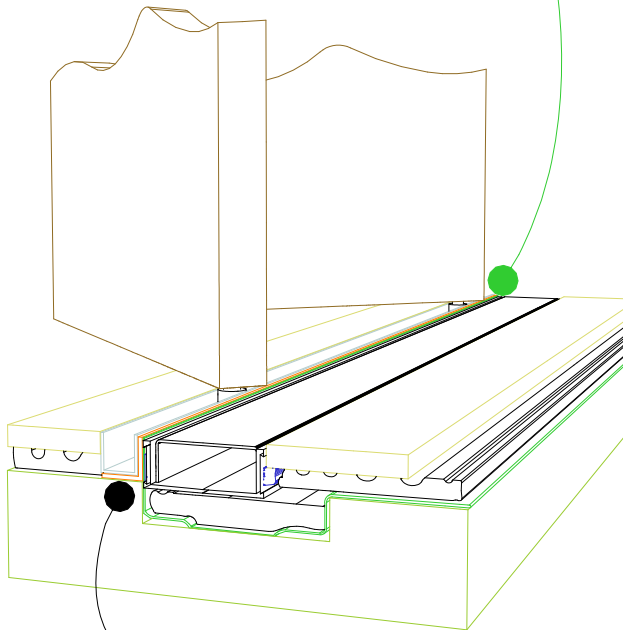

Aluminium angle to support waterproofing and junction between channel and door track.

For all types of threshold installation ensure both sides of the channel are sealed before laying tile.

NOTE, ALWAYS ensure the waterproofing is completed before laying the Stormtech.

NOTE, ensure weather strip is used on the appropriate side of the door to ensure drafts and moisture are minimised.



65G25 TIMBER FLOOR/DECK

For 65ARG25, 65MNDG25, 65PHG25, 65PSG25, 65TRG25, and 65TRTiG25.



When 65G25 is running parallel to joist/bearer

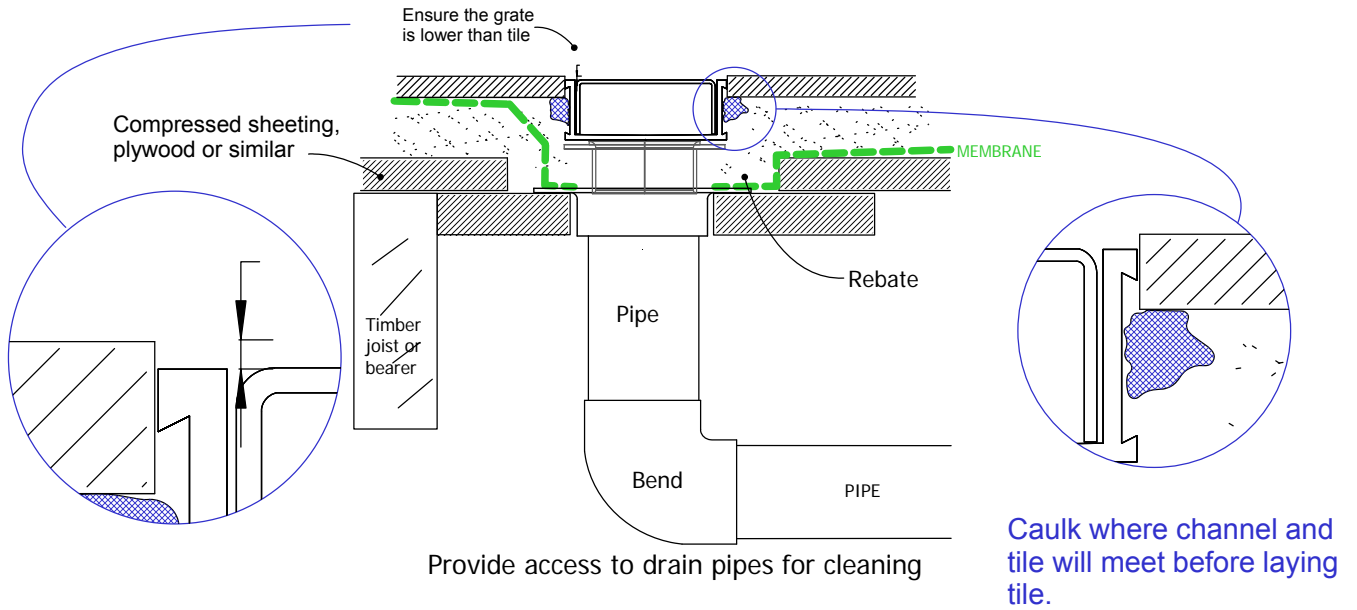

When 65G25 is running perpendicular to joist/bearer

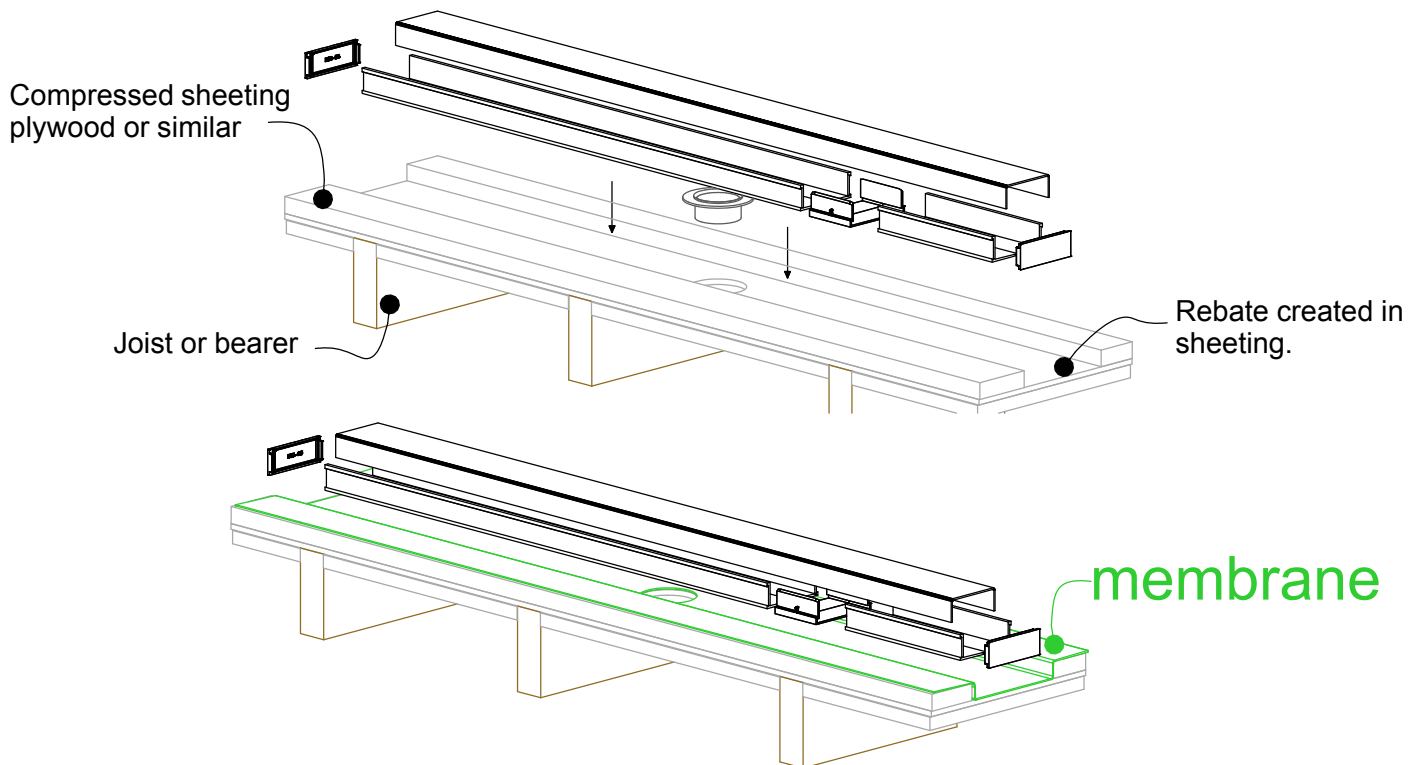

NOTE: For exterior application allow for expansion of 1mm per metre by using quality suitable flexible sealant on channel joints. Use PVC solvent cement and primer for ends and outlets.



65G25 Against Wall

For 65ARG25, 65MNDG25, 65PHG25, 65PSG25, 65TRG25, and 65TRTiG25.

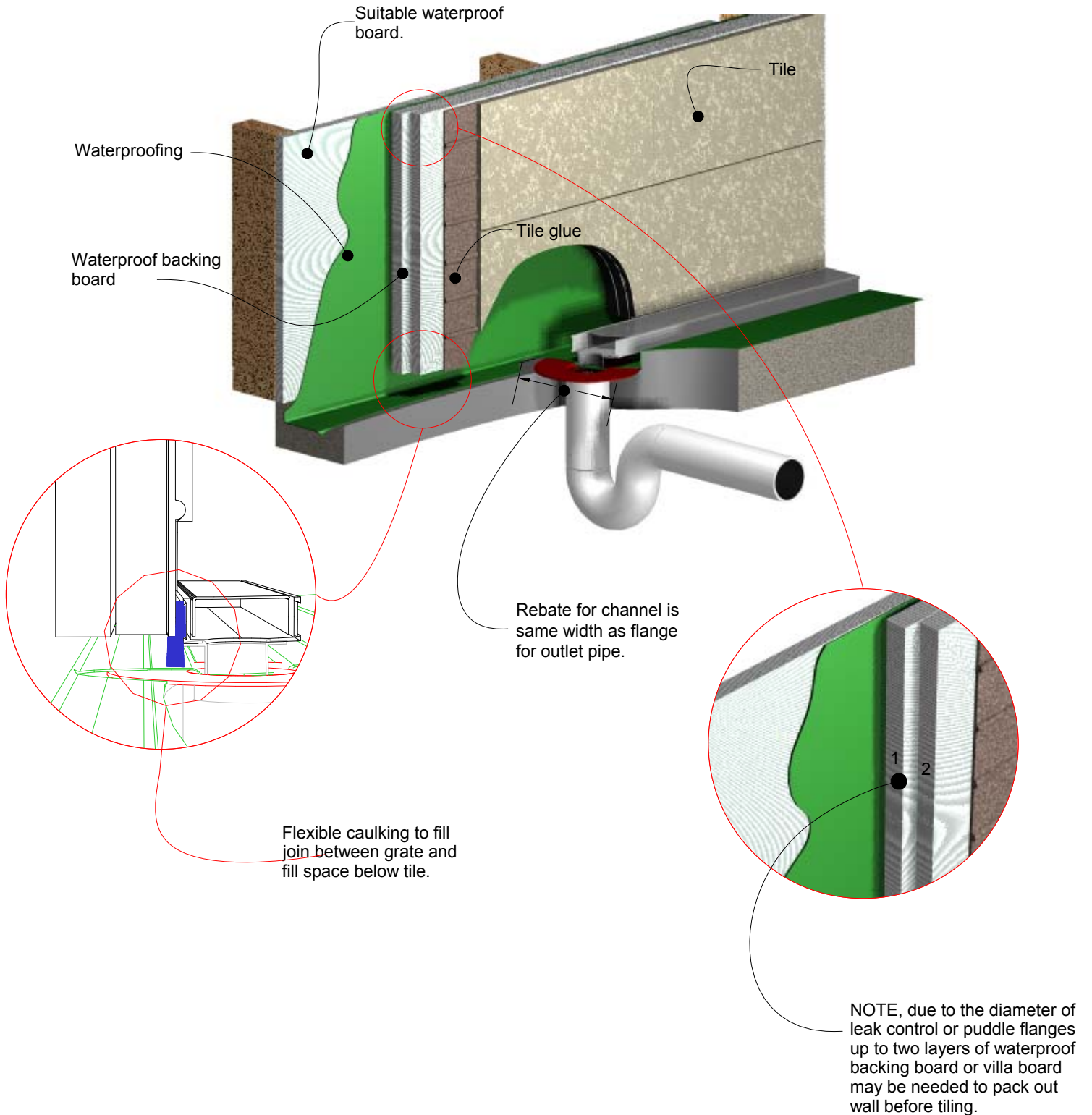

Visit slimlinedrain.co.uk

