

ARCHITECTURAL GRATES + DRAINS



100Tii40MTL

Tile Insert Drain

Stormtech is the only linear drainage system available with full Greentag and Watermark certification across our complete product range.

Telephone 01483 346460 | Web slimlinedrain.co.uk





ARCHITECTURAL
GRATES + DRAINS



100Tii40MTL

Tile Insert Drain



All stainless steel drainage unit made to specified length with specified outlet position.

The 100Tii40 is a Tile Insert Drain manufactured from 3mm thick 316 marine grade stainless steel.

Suitable for tiles up to 25mm thick.

The maximum length of the tile insert will be 1200mm in one piece, channels longer than 1200mm will have inserts in multiple equal sections

Code 100Tii40MTL

Range 100

Grate Style Ti

Category Made-to-Length

Channel Material Stainless Steel

Steel Grade 316

SPECIFICATIONS + DIMENSIONS

Channel Width	106mm
Channel Depth	42mm
Length(s)	As Required
Outlet Size	DN40, DN50, DN65, DN80, DN100

STORMTECH COLOUR FINISHES



Electroplate finishes subject to natural variation with time and local environment. Factors such as pools/surf beaches may require electropolishing. Contact us for suitability.

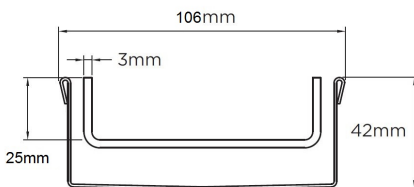

Grates longer than 1500mm supplied in sections.
Tile Inserts longer than 1200mm supplied in sections.
Channels over 3000mm supplied in sections with joiner.
+/-2mm tolerance on dimensions.

PRODUCT APPLICATIONS

- | | |
|-----------------------------|----------------------------|
| Bathroom Drainage | Hospitality Drainage |
| Aged / Health Care Drainage | Paved Area Drainage |
| Balcony Drainage | Shower Drainage |
| Commercial Drainage | Multi-Residential Drainage |
| Courtyard / Patio Drainage | Special Needs Drainage |
| Pool and Spa Area Drainage | Threshold Drainage |

Copyright © Stormtech Pty Ltd. Patent 733361. Drawings not to scale, please use dimensions shown.



Visit slimlinedrain.co.uk
for tools + inspiration.

Phone 01483 346460

Email technical@slimlinedrain.co.uk

100Tii Bathroom

For 100Tii30MTL, 100TiiCo30, 100TRTii25MTL, 100TRTiiCO25, 100Tii40MTL.

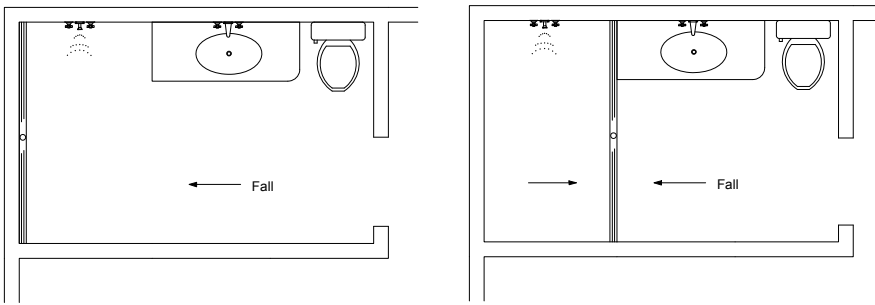

Cut tile to width and fix into tile receiver tray. To ensure no metal contamination causes spalling below the tile. It is recommended to use a paint-on waterproof membrane on the interior of the tile receiver tray before tiling to ensure no contaminants are trapped below tile tile against the stainless.

NOTE, refer to AS3500 for specific outlet pipe sizes related to your specific installation.

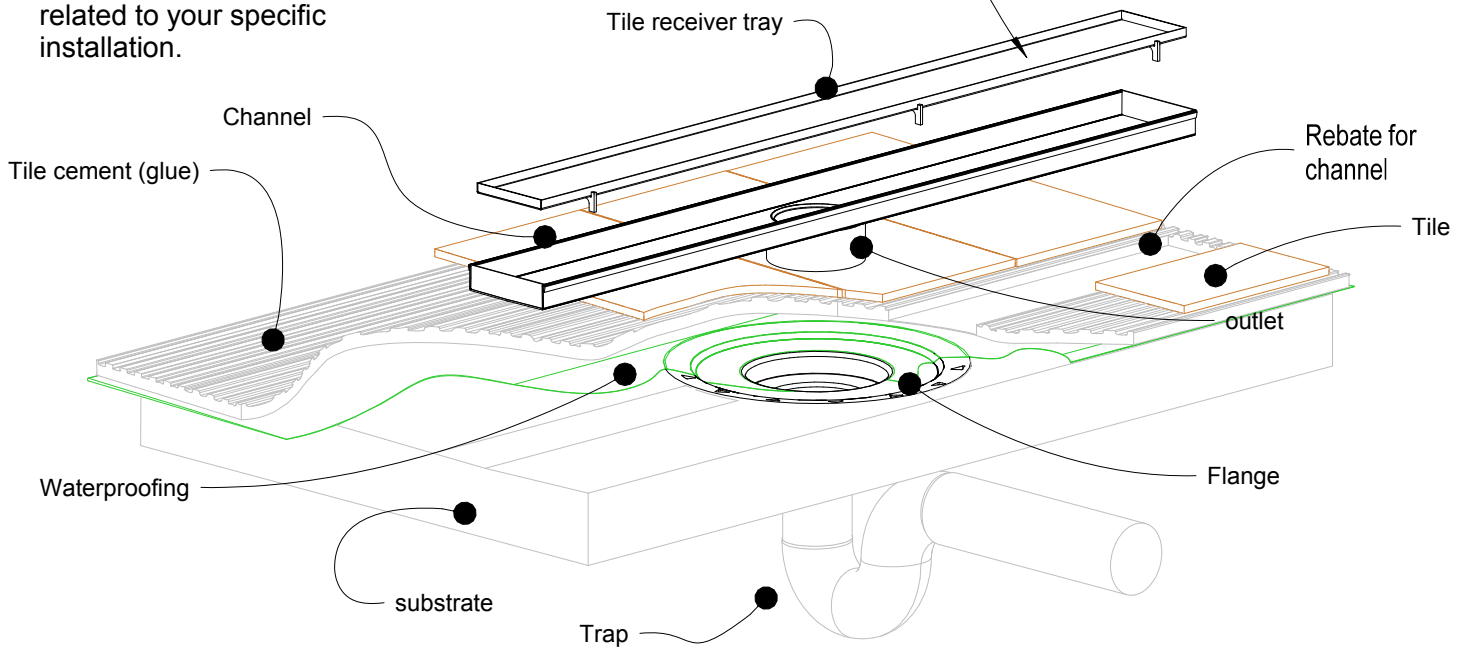

NOTE, this method requires the channel system to be ABOVE and SEPARATE from the WATERPROOFING.

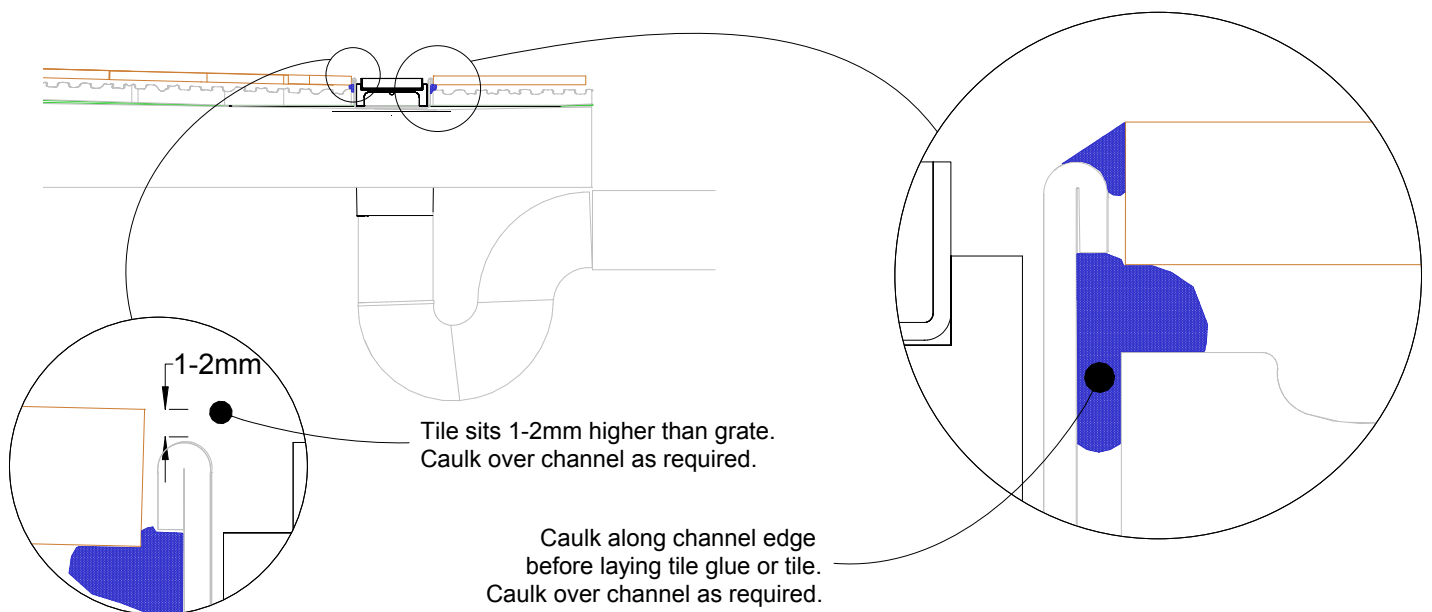

100Tii Concrete Floor or Deck

For 100Tii30MTL, 100TiiCo30, 100TRTii25MTL, 100TRTiiCO25, 100Tii40MTL.

Slab on Ground

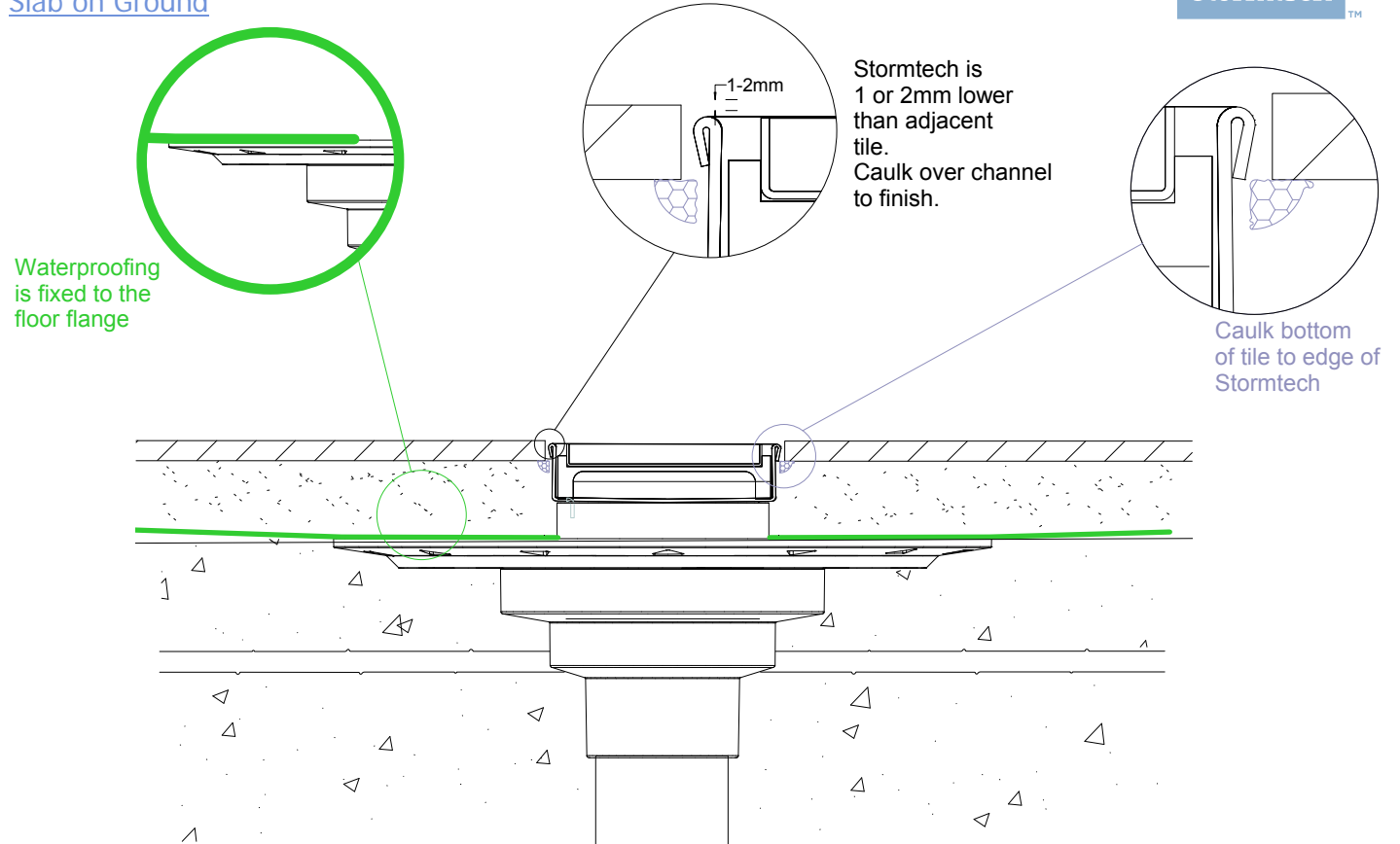

Suspended Slab

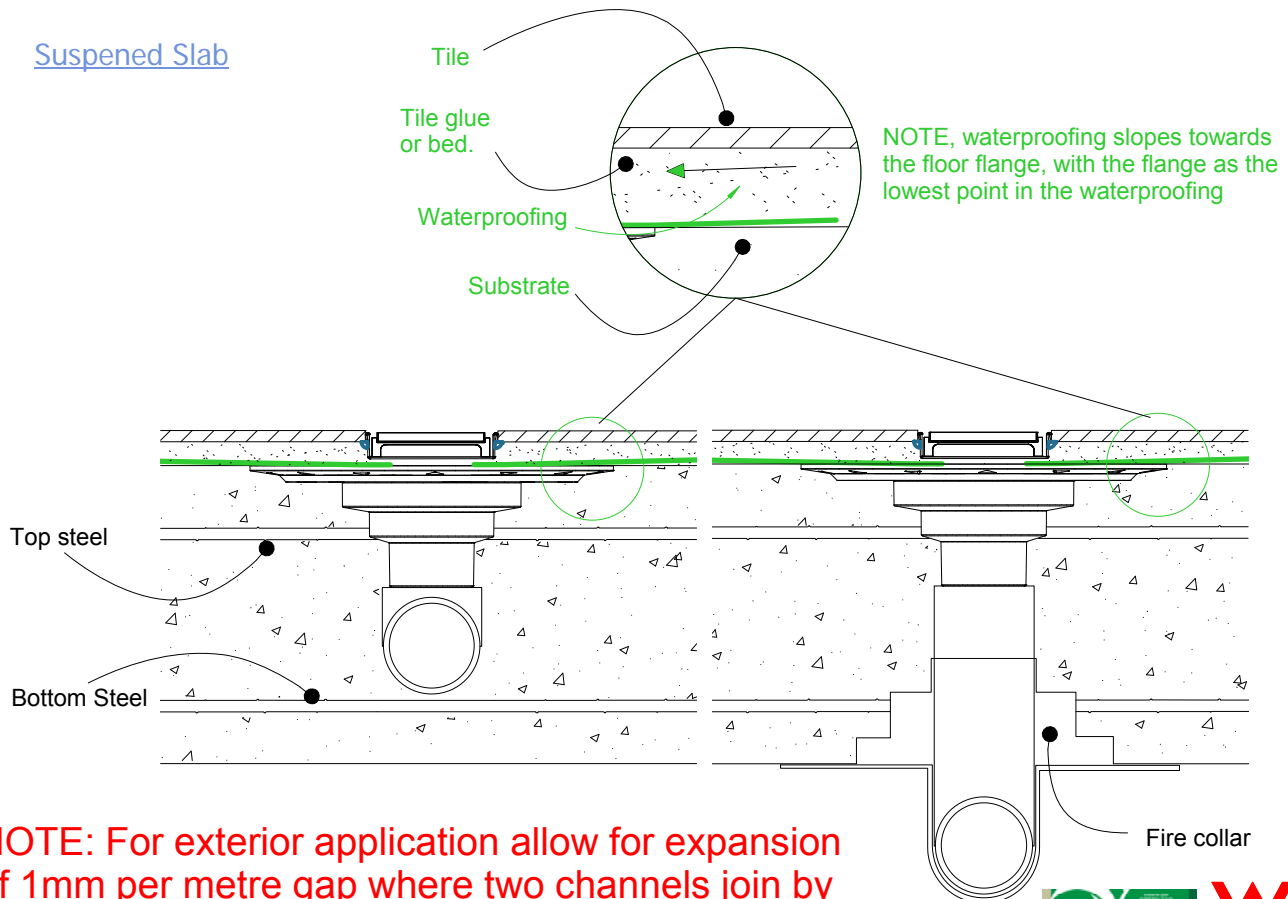

NOTE: For exterior application allow for expansion of 1mm per metre gap where two channels join by using quality suitable flexible sealant on channel joiners.



100Tii Threshold installation suggestion

For 100Tii30MTL, 100TiiCo30, 100TRTii25MTL,
100TRTiiCO25, 100Tii40MTL.



Standard hinged door

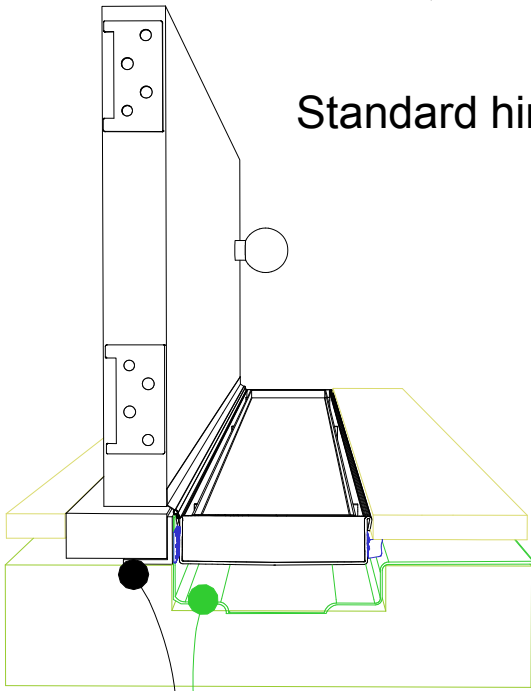

Aluminium angle to support waterproofing and junction between channel and door sil.

Top hung slider

Aluminium angle to support waterproofing and junction between channel and door track.

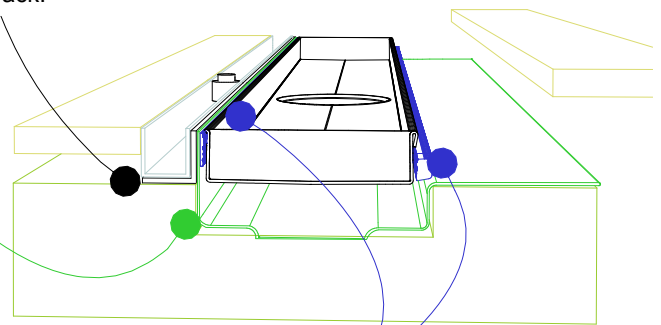
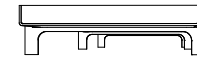

Waterproofing

For all types of threshold installation ensure both sides of the channel are sealed before laying tile.

Bi-fold door

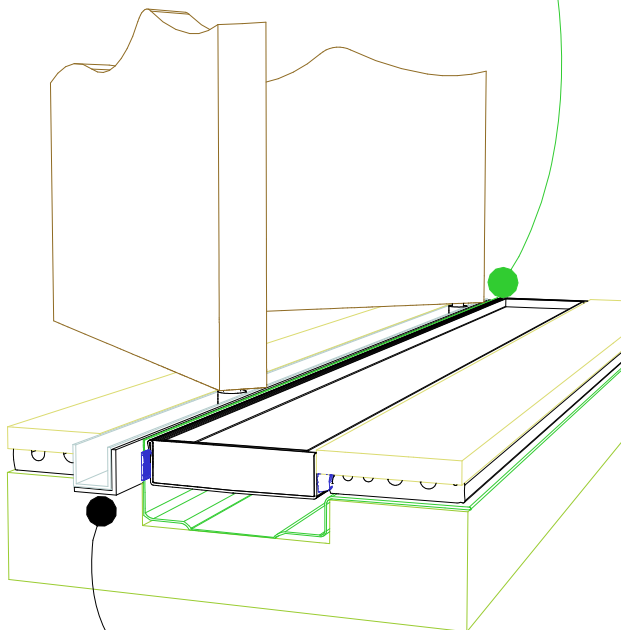

Aluminium angle to support waterproofing and junction between channel and door track.

NOTE, ensure weather strip is used on the appropriate side of the door to ensure drafts and moisture are minimised.

NOTE, ALWAYS ensure the waterproofing is completed before laying the Stormtech.



100Tii Against Wall

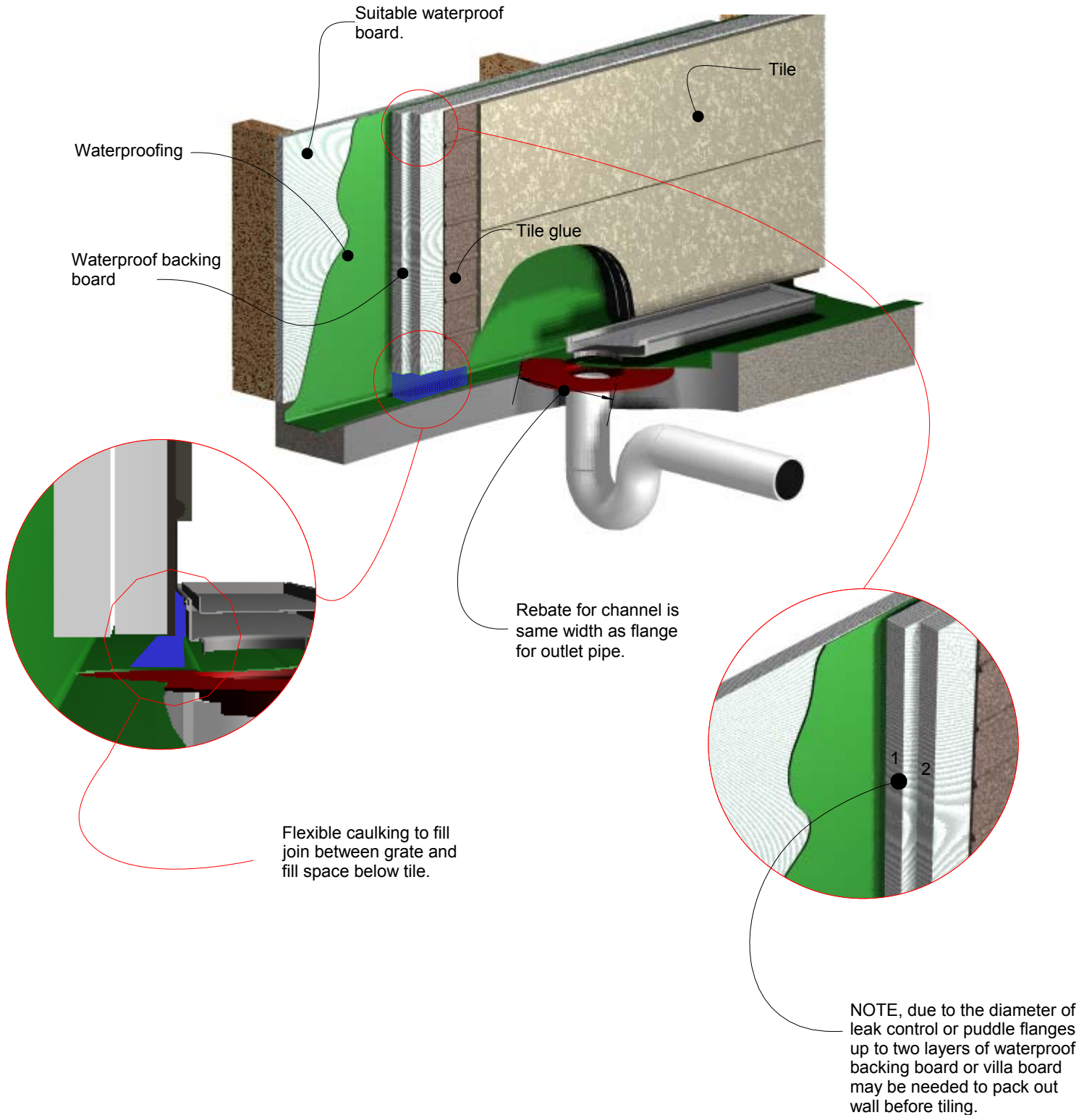

100Tii TIMBER FLOOR/DECK

For 100Tii30MTL, 100TiiCo30, 100TRTii25MTL, 100TRTiiCO25, 100Tii40MTL.



When 100Tii is running parallel to joist/bearer

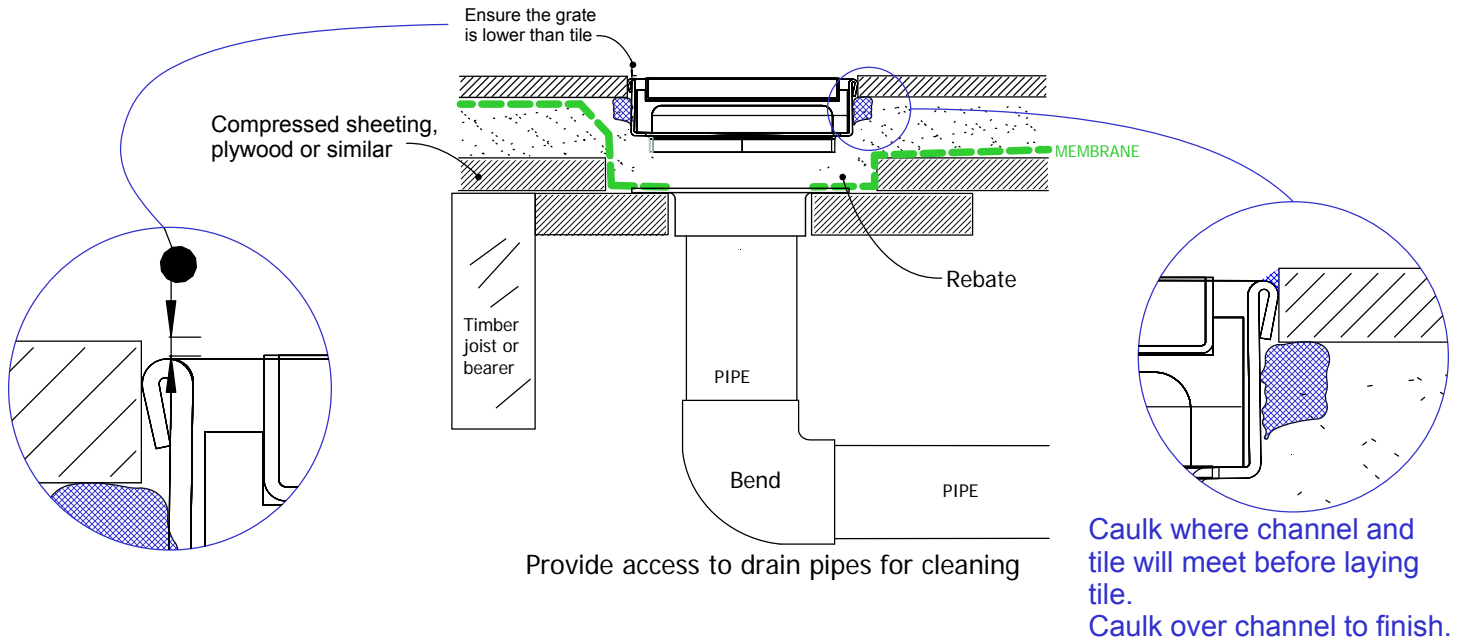

When 100Tii is running perpendicular to joist/bearer

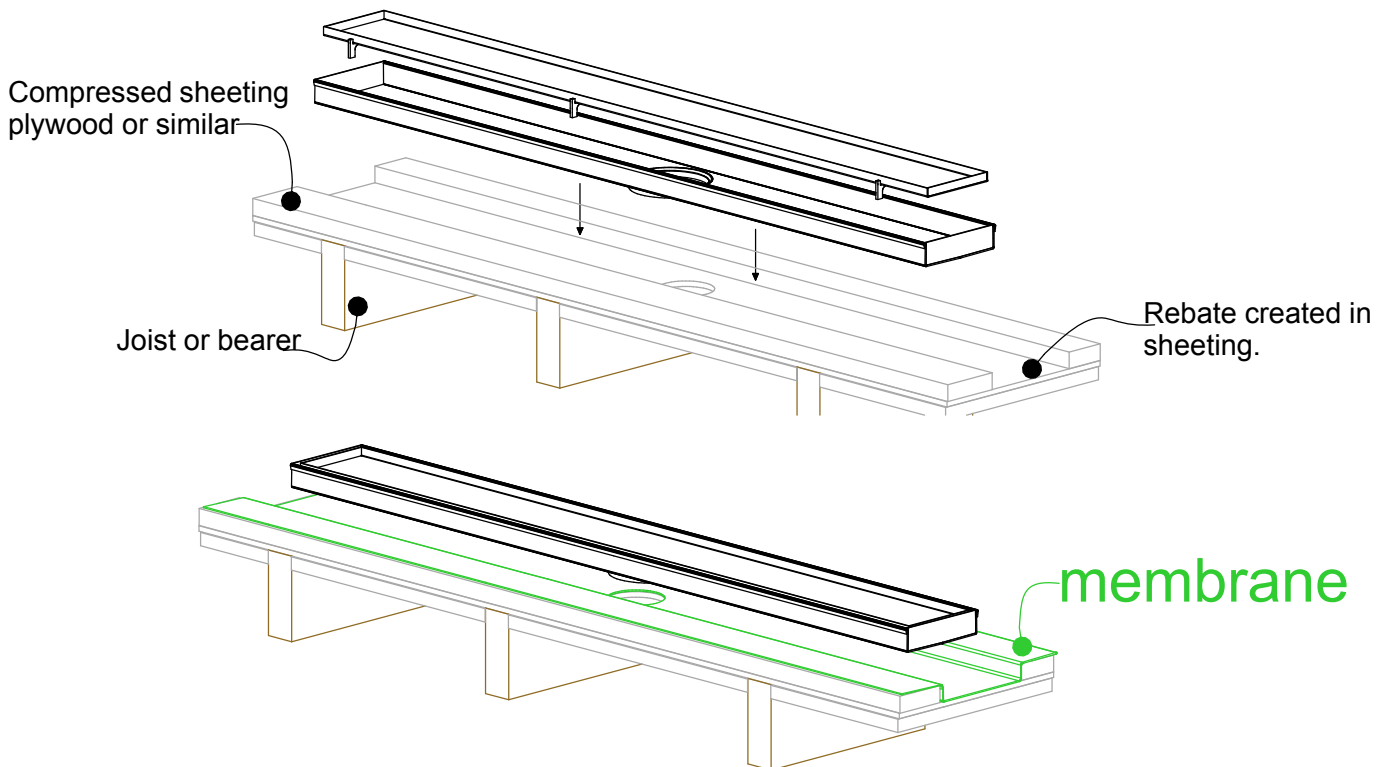

NOTE: For exterior application allow for expansion of 1mm per 3 metres by using quality suitable flexible sealant on channel joins.



Order and Quote Form

Made-to-Length Tile Insert Drain



Tray Profiles 100 Range

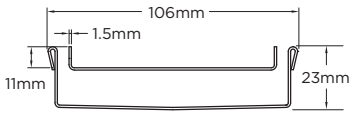

Profile 1

Suits tiles up to 10mm thick
100Tii20MTL

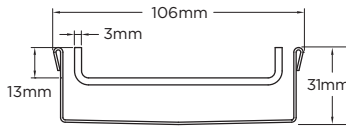

Profile 2

Suits tiles up to 12mm thick
100Tii30MTL

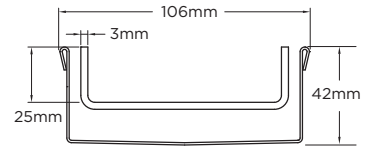

Profile 3

Suits tiles up to 25mm thick
100Tii40MTL

65 Range

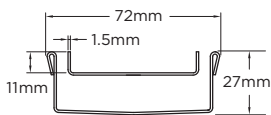

Profile 4

Suits tiles up to 10mm thick
65Tii25MTL

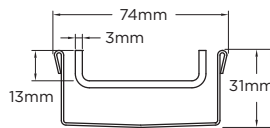

Profile 5

Suits tiles up to 12mm thick
65Tii30MTL

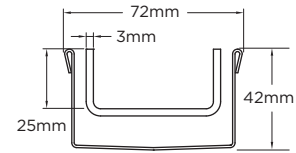

Profile 6

Suits tiles up to 25mm thick
65Tii40MTL

Specify Size, Outlet and Profile Required

Drain 1

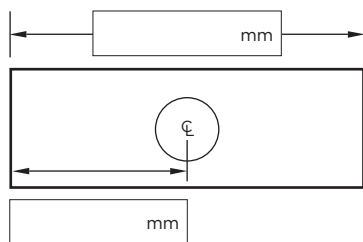

Profile Required

- 1 2 3
 4 5 6

Outlet Size

- 38mm 44mm 51mm
 63mm 76mm 89mm

Drain 2

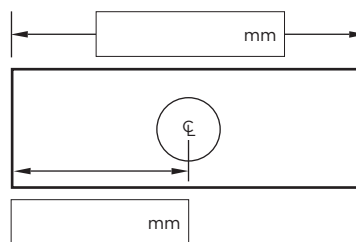

Profile Required

- 1 2 3
 4 5 6

Outlet Size

- 38mm 44mm 51mm
 63mm 76mm 89mm

Drain 3

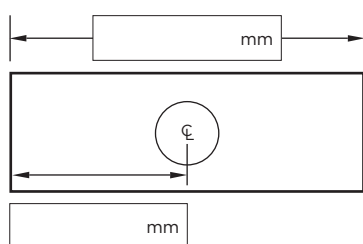

Profile Required

- 1 2 3
 4 5 6

Outlet Size

- 38mm 44mm 51mm
 63mm 76mm 89mm

Please Note

See AS3500 standard & local regulator for specific outlet/drain requirements. Outlet Size must be smaller than selected Range. Stainless Steel Grade is 316 unless specified. Made-to-Length (MTL) minimum charge of 800mm. Tile Inserts longer than 1200mm are supplied in multiple sections. Channels are a maximum 3000mm in one piece, channels over 3000mm are supplied in multiple sections with joiner. +/- 2mm tolerance on dimensions.

Full Name

Company Name

Telephone

Email Address

Order Number

Stormtech Quote Number

Signature

Phone 01483 346 460

Email technical@slimlinedrain.co.uk

slimlinedrain.co.uk

Order and Quote Form

Made-to-Length Tile Insert Drain › Multiple Outlet



Tray Profiles 100 Range

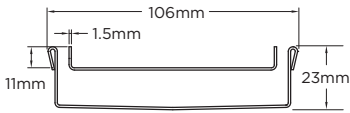

Profile 1

Suits tiles up to 10mm thick
100Tii20MTL

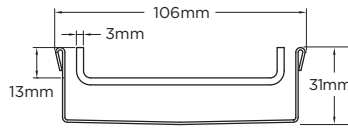

Profile 2

Suits tiles up to 12mm thick
100Tii30MTL

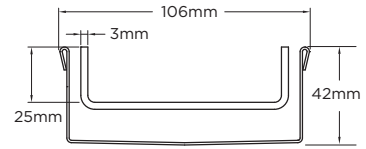

Profile 3

Suits tiles up to 25mm thick
100Tii40MTL

65 Range

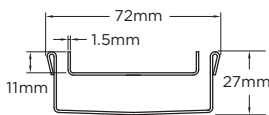

Profile 4

Suits tiles up to 10mm thick
65Tii25MTL

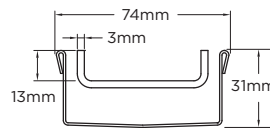

Profile 5

Suits tiles up to 12mm thick
65Tii30MTL

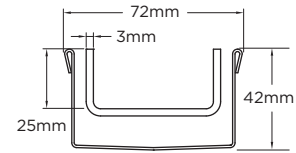

Profile 6

Suits tiles up to 25mm thick
65Tii40MTL

Specify Length, Outlet Positions/Size and Profile Required

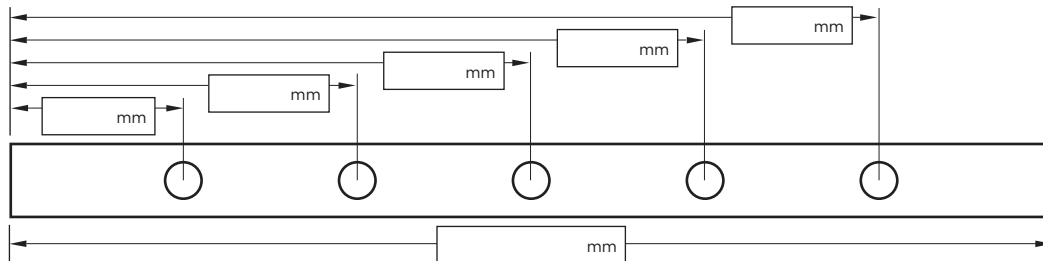

Drain 1

Profile Required

1 2 3 4

Outlet Size

38mm 44mm 51mm
 63mm 76mm 89mm

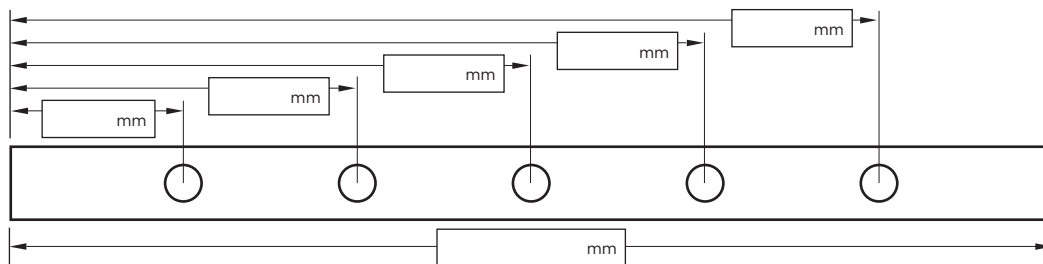

Drain 2

Profile Required

1 2 3 4

Outlet Size

38mm 44mm 51mm
 63mm 76mm 89mm

NOTE: See AS3500 standard & local regulator for specific outlet/drain requirements. Outlet Size must be smaller than selected Range. Stainless Steel Grade is 316 unless specified. Made-to-Length (MTL) minimum charge of 800mm. Tile Inserts longer than 1200mm supplied in multiple sections. Channels over 3000mm are supplied in multiple sections with joiner. +/- 2mm tolerance on dimensions.

Full Name

Company Name

Telephone

Email Address

Order Number

Stormtech Quote Number

Signature

Phone 01483 346 460

Email technical@slimlinedrain.co.uk

slimlinedrain.co.uk

Visit slimlinedrain.co.uk

